

**TTK 52 E**

**EN**

**INSTRUCTIONS**  
DEHUMIDIFIER



 **TROTEC**

**Table of contents**

**Information on the use of these instructions** ..... 2

**Safety** ..... 2

**Information about the device**..... 5

**Transport and storage**..... 6

**Assembly and start-up**..... 7

**Operation** ..... 8

**Errors and faults**..... 10

**Maintenance** ..... 11

**Technical annex**..... 14

**Disposal** ..... 17

**Information on the use of these instructions**

**Symbols**



**Danger**

This symbol indicates dangers to the life and health of persons due to extremely flammable gas.



**Warning of electrical voltage**

This symbol indicates dangers to the life and health of persons due to electrical voltage.



**Warning**

This signal word indicates a hazard with an average risk level which, if not avoided, can result in serious injury or death.



**Caution**

This signal word indicates a hazard with a low risk level which, if not avoided, can result in minor or moderate injury.

**Notice**

This signal word indicates important information (e.g. material damage), but does not indicate hazards.



**Info**

Information marked with this symbol helps you to carry out your tasks quickly and safely.



**Follow the manual**

Information marked with this symbol indicates that the instructions must be observed.

You can download the current version of the instructions and the EU declaration of conformity via the following link:



TTK 52 E



<https://hub.trotec.com/?id=41395>

**Safety**

**Read this manual carefully before starting or using the device. Always store the manual in the immediate vicinity of the device or its site of use.**



**Warning**

**Read all safety warnings and all instructions.**

Failure to follow the warnings and instructions may result in electric shock, fire and/or serious injury.

**Save all warnings and instructions for future reference.**

This appliance can be used by children aged from 8 years and above and persons with reduced physical, sensory or mental capabilities or lack of experience and knowledge if they have been given supervision or instruction concerning use of the appliance in a safe way and understand the hazards involved.

Children shall not play with the appliance. Cleaning and user maintenance shall not be made by children without supervision.

- Do not use the device in potentially explosive rooms or areas and do not install it there.
- Do not use the device in aggressive atmosphere.
- Place the device in an upright and stable position on horizontal and stable ground.
- Let the device dry out after a wet clean. Do not operate it when wet.
- Do not use the device with wet or damp hands.
- Do not expose the device to directly squirting water.
- Do not cover the device during operation.
- Do not sit on the device.
- This appliance is not a toy. Keep away from children and animals.
- Occasionally observe the device during operation.
- Check accessories and connection parts for possible damage prior to every use of the device. Do not use any defective devices or device parts.

- Ensure that all electric cables outside of the device are protected from damage (e.g. caused by animals). Never use the device if electric cables or the power connection are damaged!
- The mains connection must correspond to the specifications in the Technical annex.
- Insert the mains plug into a properly fused mains socket.
- Observe the device's power input, cable length and intended use when selecting extensions to the power cable. Completely unroll extension cables. Avoid electrical overload.
- Do not under any circumstances use the device if you detect damages on the mains plug or power cable. If the power cable is damaged, it must be replaced by the manufacturer, its service agent or similarly qualified persons in order to avoid a hazard. Defective power cables pose a serious health risk!
- Before carrying out maintenance, care or repair work on the device, remove the mains plug from the mains socket. Hold onto the mains plug while doing so.
- Switch the device off and disconnect the power cable from the mains socket when the device is not in use.
- When positioning the device, observe the minimum distances from walls and other objects as well as the storage and operating conditions specified in the Technical annex.
- Make sure that the air inlet and outlet are not obstructed.
- Make sure that the suction side is kept free of dirt and loose objects.
- Never insert any objects or limbs into the device.
- Do not remove any safety signs, stickers or labels from the device. Keep all safety signs, stickers and labels in legible condition.
- Only transport the device in an upright position with an emptied condensation tank or drain hose.
- Discharge the collected condensate before transport and storage. Do not drink it. Health hazard!
- Only use original spare parts, for otherwise safe and functional operation cannot be ensured.



### **Safety warnings for devices containing flammable refrigerants**

- Only position the device in rooms where potentially leaking refrigerant cannot accumulate. Unventilated rooms, in which the device is installed, operated or stored, must be built in a way to ensure that potentially leaking refrigerant cannot accumulate. This serves to avoid fire or explosion hazards resulting from an ignition of the refrigerant by an electric furnace, cooking stove or another ignition source.
- Only position the device in rooms where there is no source of ignition (e.g. open flames, an active gas appliance or an electric heater).
- Please note that the refrigerant is odourless.
- Only install the device in compliance with the national installation regulations.
- Please observe the local regulations.
- Observe the national gas regulations.
- Only install, operate and store the device in a room measuring more than 4 m<sup>2</sup>.
- Store the device in a way that no mechanical damage can occur.
- Please note that the connected pipelines must not contain any sources of ignition.
- Please note that the connected air ducts must not contain any sources of ignition.
- R290 is a refrigerant that complies with European environmental regulations. No part of the cooling circuit may be perforated.
- Observe the maximum refrigerant capacity in the technical data.
- Do not drill through or burn.
- Do not use any means other than those recommended by the manufacturer for accelerating the defrosting process.
- Every person working with or at the refrigerant circuit must be able to provide a certificate of qualification issued by a body accredited by the industry, demonstrating their competence in the safe use of refrigerants based on a procedure well-known in the industry.
- Service work may only be carried out in accordance with the manufacturer's specifications. If maintenance and repair work require the support of additional persons, the person trained in handling flammable refrigerants shall continuously supervise the work carried out.
- The entire refrigerant circuit is a maintenance-free, hermetically sealed system and may only be maintained or repaired by specialist companies for cooling and air-conditioning or by the manufacturer.

## Intended use

Only use the device for drying and dehumidifying room air, while adhering to and following the technical data.

In addition, the device may also be used as a kind of clothes dryer to dry wet laundry.

Intended use comprises:

- dehumidifying and drying:
  - living rooms, bedrooms and basements
  - bathrooms
  - holiday homes, caravans
- maintaining the dryness of:
  - storage spaces, archives, laboratories, garages
  - changing rooms etc.

Any use other than the intended use is regarded as misuse.

## Reasonably foreseeable misuse

- The device is not intended for industrial use.
- Do not place any objects, e.g. clothing, on the device.
- Do not use the device out of doors.
- Do not use the device in the immediate vicinity of swimming pools, bathtubs and showers.
- Never immerse the device in water.
- Do not make any unauthorised modifications, alterations or structural changes to the device.
- Do not place the device on wet or flooded ground, e.g. near floor drains.

## Personnel qualification

People who use this device must:

- be aware of the dangers that occur when working with electric devices in damp areas.
- have read and understood the instructions, especially the Safety chapter.

Maintenance tasks which require the housing to be opened must only be carried out by specialist companies for cooling and air-conditioning or by the manufacturer.

## Safety signs and labels on the device

### Notice

Do not remove any safety signs, stickers or labels from the device. Keep all safety signs, stickers and labels in legible condition.

The following safety signs and labels are attached to the device:

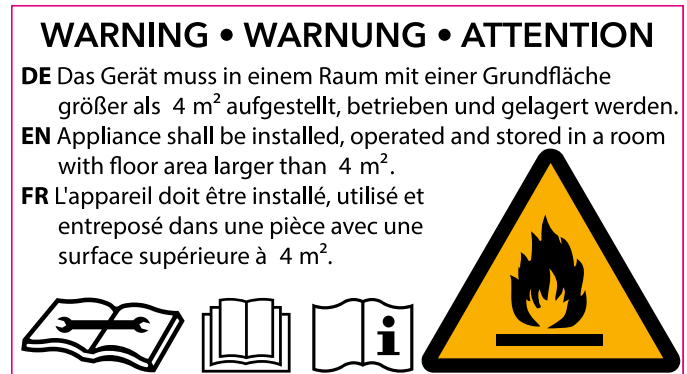

### Follow the manual

This symbol indicates that the instructions must be observed.



### Follow the repair manual

Disposal, maintenance and repair work of the refrigerant circuit may only be carried out in accordance with the manufacturer's specifications and by persons having a certificate of qualification. A corresponding repair manual is available from the manufacturer upon request.

## Residual risks



### Danger

#### Natural refrigerant propane (R290)!

H220 – Extremely flammable gas.

H280 – Contains gas under pressure; may explode if heated.

P210 – Keep away from heat, sparks, open flames and other ignition sources. No smoking.

P377 – Leaking gas fire: Do not extinguish, unless leak can be stopped safely.

P410+P403 – Protect from sunlight. Store in a well-ventilated place.



### Warning of electrical voltage

Work on the electrical components must only be carried out by an authorised specialist company!



### Warning of electrical voltage

Risk of electric shock!

The device is not protected against water.

There is a risk of electric shock!

Never use the device in areas where dripping, spraying or running water can enter the device! Never immerse the device in water!



### Warning of electrical voltage

Risk of electric shock!

Risk of an electric shock if the device comes into contact with water!

Do not use this device in the immediate vicinity of bathtubs, showers or swimming pools!



### Warning of electrical voltage

Before any work on the device, remove the mains plug from the mains socket!

Do not touch the mains plug with wet or damp hands.

Hold onto the mains plug while pulling the power cable out of the mains socket.



### Warning

Dangers can occur at the device when it is used by untrained people in an unprofessional or improper way! Observe the personnel qualifications!



### Warning

The device is not a toy and does not belong in the hands of children.



### Warning

Risk of suffocation!

Do not leave the packaging lying around. Children may use it as a dangerous toy.

### Notice

Do not operate the device without an air filter inserted into the air inlet!

Without the air filter, the inside of the device will be heavily contaminated. This can reduce the performance and result in damage to the device.

## Behaviour in the event of an emergency

1. Switch the device off.
2. Disconnect the device from the mains: Hold onto the mains plug while pulling the power cable out of the mains socket.
3. Do not reconnect a defective device to the mains.

## Information about the device

### Device description

The device uses the principle of condensation to automatically dehumidify rooms.

The fan sucks damp room air through the air inlet, the air filter, the evaporator and to the condenser located behind it. The air is cooled at the cold evaporator until it is below the dew point. Water vapour contained in the room air precipitates on the evaporator fins as condensation or rime. The dehumidified, cooled air is slightly warmed at the condenser and blown out again. The drier air thus conditioned mixes with the air in the room. The humidity in the room where the device is positioned is reduced as air constantly circulates through the device.

Depending on the air temperature and the relative humidity, the condensed water either drops continuously or only during the defrost phase through the integrated drain nozzle into the condensation tank below. It is fitted with a float to measure the filling level.

The device has a control panel for operating and controlling the functions.

Once the maximum filling level of the condensation tank is reached or in case the condensation tank is not installed correctly, the *BUCKET FULL* indication (12, see chapter Operating elements) on the control panel is illuminated. The device switches off. The indication only goes out again once the emptied condensation tank is reinserted.

Optionally, the condensed water can be drained by attaching a hose at the condensation connection.

The device can reduce the relative humidity of a room to approx. 30 %.

Because of the heat radiation generated during operation, the room temperature may rise slightly.

The device is not protected against water (IPX0).

**Device depiction**

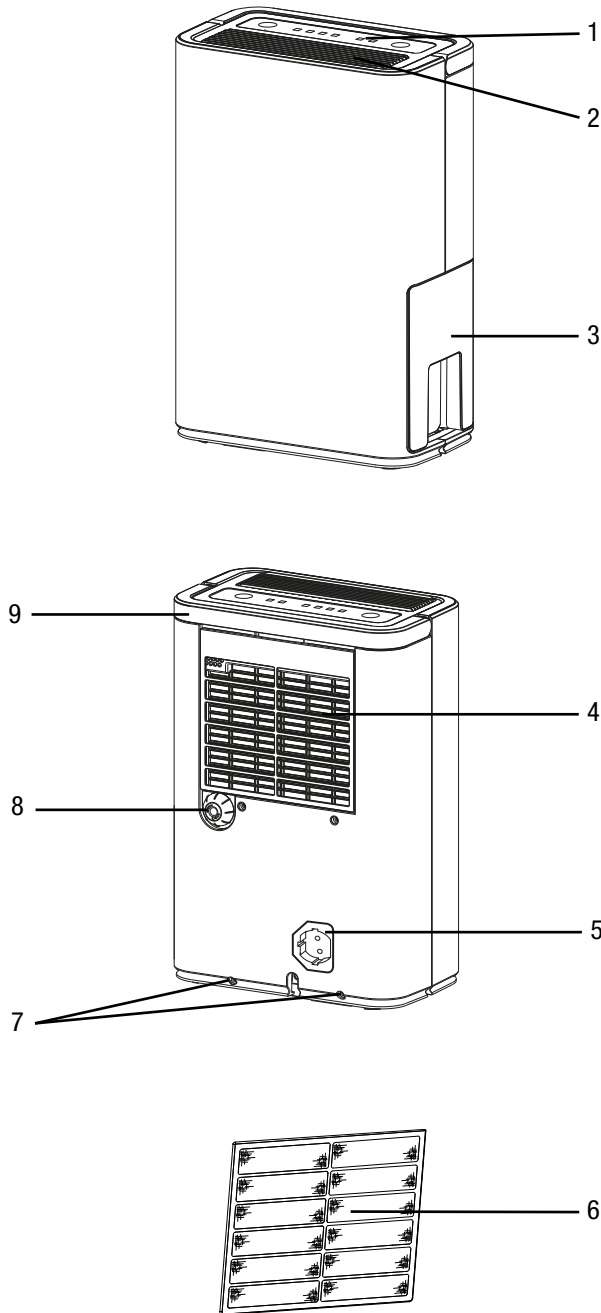

No.	Designation
1	Control panel
2	Air outlet
3	Condensation tank
4	Air inlet with air filter
5	Mains plug holder
6	Air filter
7	Feet
8	Condensation hose connection with sealing cap
9	Transport handle

**Transport and storage**

**Notice**

If you store or transport the device improperly, the device may be damaged.  
 Note the information regarding transport and storage of the device.

**Transport**

Please note that additional transport regulations might apply to devices containing flammable refrigerants. The equipment's arrangement and the maximum number of components to be transported together can be gathered from the applicable transport regulations.

To make the device easier to transport, it is fitted with a carry handle.

**Before** transporting the device, observe the following:

- Switch the device off.
- Hold onto the mains plug while pulling the power cable out of the mains socket.
- Drain the remaining condensate from the device and the condensation drain hose (see chapter Maintenance).
- Do not use the power cable to drag the device.

**After** transporting the device, proceed as follows:

- Set up the device in an upright position after transport.

**Storage**

**Before** storing the device, proceed as follows:

- Drain the remaining condensate from the device and the condensation drain hose (see chapter Maintenance).
- Hold onto the mains plug while pulling the power cable out of the mains socket.

When the device is not being used, observe the following storage conditions:

- Only store the device in a room measuring more than 4 m<sup>2</sup>.
- Only position the device in rooms where there is no source of ignition (e.g. open flames, an active gas appliance or an electric heater).
- Store the device in a dry location and protected from frost and heat.
- Store the device in an upright position where it is protected from dust and direct sunlight.
- If required, use a cover to protect the device from invasive dust.
- Place no further devices or objects on top of the device to prevent it from being damaged.

## Assembly and start-up

### Scope of delivery

- 1 x Device
- 1 x Air filter
- 1 x Manual

### Unpacking the device

1. Open the cardboard box and take the device out.
2. Completely remove the packaging.
3. Fully unwind the power cable. Make sure that the power cable is not damaged and that you do not damage it during unwinding.

### Start-up

When positioning the device, observe the minimum distance from walls or other objects as described in the chapter Technical annex.

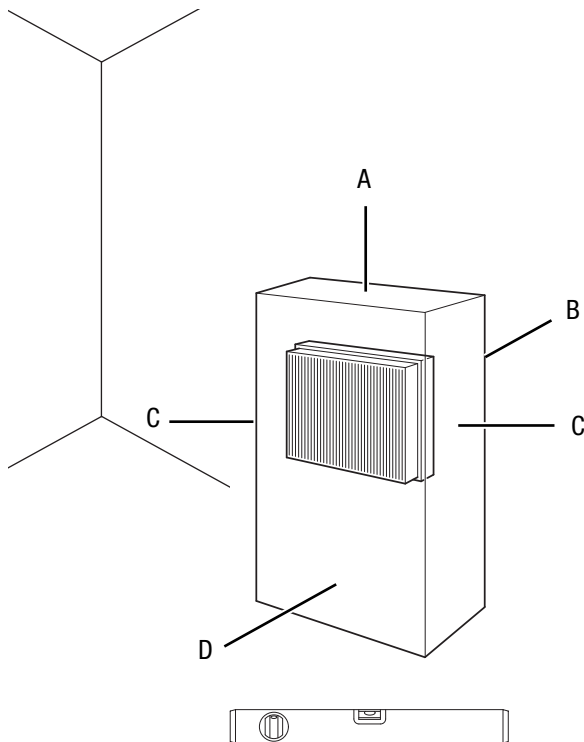

- Before restarting the device, check the condition of the power cable. If there are doubts as to the sound condition, contact the customer service.
- Only position the device in rooms where potentially leaking refrigerant cannot accumulate.
- Only position the device in rooms where there is no source of ignition (e.g. open flames, an active gas appliance or an electric heater).
- Place the device in an upright and stable position on horizontal and stable ground.

- Do not create tripping hazards when laying the power cable or other electric cables, especially when positioning the device in the middle of the room. Use cable bridges.
- Make sure that extension cables are completely unrolled.
- When positioning the device, keep a sufficient distance to heat sources.
- Make sure that no curtains or other objects interfere with the air flow.

### Inserting the air filter

#### Notice

Do not operate the device without an air filter inserted into the air inlet!

Without the air filter, the inside of the device will be heavily contaminated. This can reduce the performance and result in damage to the device.

- Make sure that the air filter is installed before switching the device on.

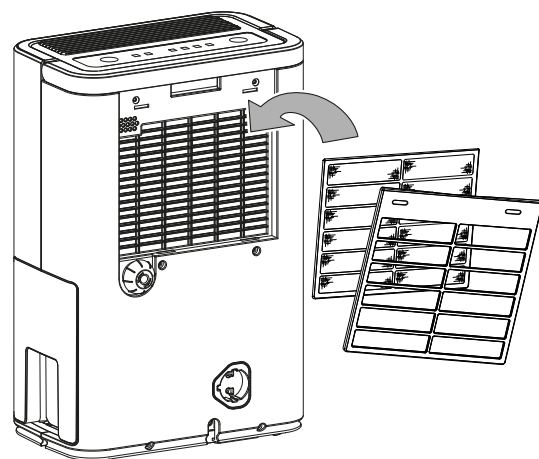

### Inserting the condensation tank

- Ensure that the float inside the condensation tank is inserted correctly.
- Ensure that the condensation tank is empty and inserted correctly.

### Connecting the power cable

- Insert the mains plug into a properly secured mains socket.

**Operation**

**Notes:**

- Avoid open doors and windows.
- After being switched on, the device operates fully automatically.
- The fan permanently runs in dehumidification mode even after the set nominal value has been reached until the device is switched off.

**Operating elements**

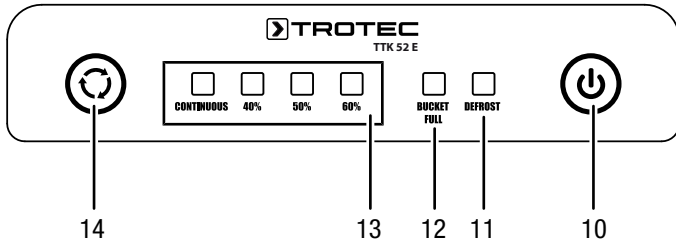

No.	Designation	Meaning
10	Power button	Power button: Switches the device on or off.
11	DEFROST indication	Illuminated when automatic defrosting is in progress.
12	BUCKET FULL indication	Illuminated when the condensation tank is full or not installed correctly.
13	Room humidity indication	Indicates the desired relative room humidity. Display sequence: 60 % -> 50 % -> 40 % -> CONTINUOUS (continuous operation)
14	Operating mode button	Selection button for the desired relative room humidity in dehumidification mode and continuous operation Switch sequence: 60% -> 50% -> 40% -> CONTINUOUS -> 60%



**Warning of electrical voltage**

Risk of electric shock!  
The device is not protected against water.  
There is a risk of electric shock!  
Never use the device in areas where dripping, spraying or running water can enter the device! Never immerse the device in water!

**Switching the device on**

Once you have completely installed the device as described in the chapter Assembly and start-up, you can switch it on.

1. Press the *Power* button (10).  
⇒ The unit starts to *dehumidify*.

**Setting the operating mode**

- Dehumidification
- Continuous operation

**Setting the desired relative room humidity**

You can change the desired relative room humidity at any time.

1. Press the *operating mode* button (14) to set the desired room humidity. Setting is possible in the range between 40 % and 60 % in increments of 10 %.  
⇒ The desired relative room humidity lights up in the *room humidity* indication (13).

**Dehumidification**

The device keeps running until reaching the desired relative room humidity. Then the compressor switches off and the fan keeps running. Once the desired relative room humidity is exceeded, the compressor switches back on.

The desired relative room humidity can be preselected at any time. Setting is possible in the range between 40 % and 60 % in increments of 10 %.

1. Press the *operating mode* button (14) until the desired room humidity is displayed.  
⇒ The LED for the selected room humidity level will be illuminated.  
⇒ *Dehumidification* mode is selected.

**Continuous operation**

The device dehumidifies the air constantly and regardless of the relative room humidity.

The desired relative room humidity cannot be adjusted in this operating mode.

1. Press the *operation mode* button (14) until the *CONTINUOUS* indication lights up.  
⇒ The *CONTINUOUS* indication is illuminated.  
⇒ *Continuous operation* is selected.

**Auto stop function**

If the water tank is full, not inserted correctly or the desired relative room humidity has been reached, the device will stop automatically.



### Operation with hose attached to the condensation connection

For continuous operation or unattended dehumidification, please connect a suitable condensation drain hose to the device.

- ✓ A suitable hose (diameter: 13 mm) is ready for use.
- ✓ The device is switched off.

1. Unscrew the sealing cap from the hose connection and remove the rubber stopper.

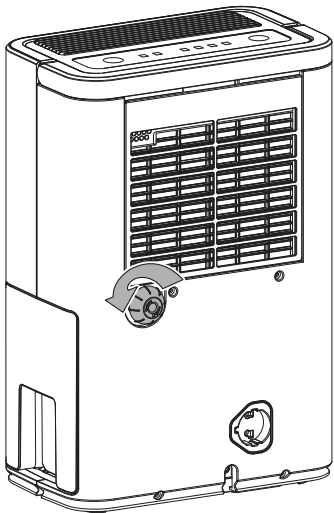

2. Push one end of the hose onto the hose connection.

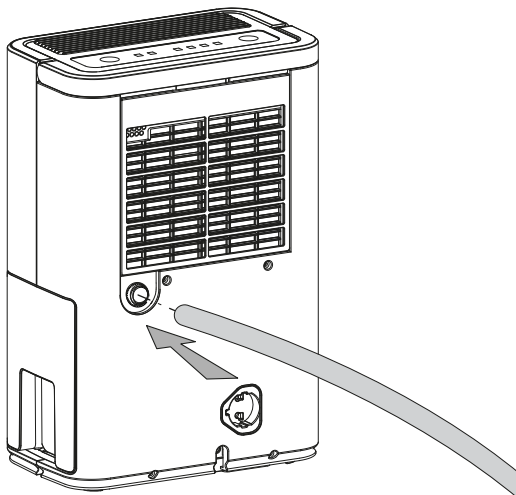

3. Guide the other hose end to a suitable drain or sufficiently dimensioned collection container. Please note that the hose must not be kinked.

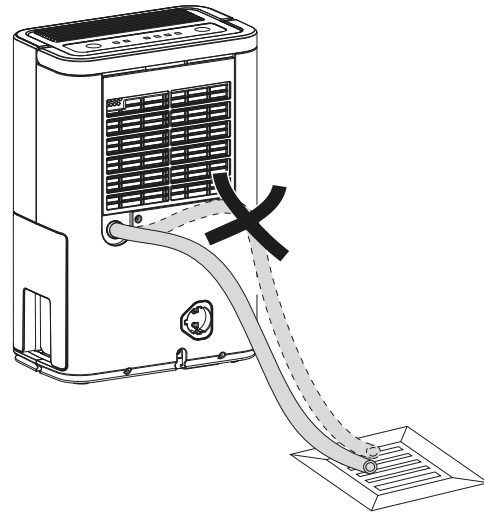

4. Remove the hose if you want to collect the condensate in the condensation tank again. Allow the hose to dry prior to storage.
  - ⇒ The hose can be connected in any operating mode for continuous operation.
5. Reinsert the rubber stopper in the hose connection and reattach the sealing cap.

### Automatic defrost

At low ambient temperatures (below 12 °C), ice may form at the evaporator during dehumidification. The device will then carry out an automatic defrost. Dehumidification is briefly interrupted during defrosting.



#### Info

We do not recommend operating the device at temperatures below 5 °C.

The duration of the defrost process can vary. Do **not** switch off the device during automatic defrost. Do **not** remove the mains plug from the mains socket.

The *DEFROST* indication (11) is illuminated during automatic defrosting.

## Drying laundry

In addition, the device may also be used as a kind of clothes dryer to dry wet laundry in living or working spaces.

When positioning the device or a clothes horse, please observe the minimum distances specified in the technical data.

The following humidity values are suitable for drying laundry:

- cupboard dry = 46 % relative humidity
- iron dry = 58 % relative humidity
- slightly dried = 65 % relative humidity

Adjust the settings for the relative humidity level to the device (e.g. 60 % relative humidity for iron dry laundry). If necessary, use a measuring device to determine the humidity level.

## Shutdown



### Warning of electrical voltage

Do not touch the mains plug with wet or damp hands.

- Switch off the device.
- Hold onto the mains plug while pulling the power cable out of the mains socket.
- If necessary, remove the condensation drain hose and any residual fluid from it.
- Empty the condensation tank, if need be.
- Clean the device according to the Maintenance chapter.
- Store the device according to the Transport and storage chapter.

## Errors and faults

The device has been checked for proper functioning several times during production. If malfunctions occur nonetheless, check the device according to the following list.

### Notice

Wait for at least 3 minutes after maintenance and repair work. Only then switch the device back on.

### The device does not start:

- Check the power connection.
- Check the power cable and mains plug for damage.
- Check the on-site fusing.
- Check the condensation tank for correct seating.
- Check the room temperature. Observe the device's permissible operating range according to the technical data.

### The device is running, but there is no formation of condensate:

- Check the float in the condensation tank for dirt. If necessary, clean the condensation tank. The float must be able to move freely.

- Check the room temperature. Observe the device's permissible operating range according to the technical data.
- Ensure that the relative room humidity complies with the technical data.
- Check the preselected relative room humidity. The humidity in the room must be above the selected range.
- Check the air filter for dirt. If necessary, clean or replace the air filter.
- From the outside, check the condenser for dirt (see chapter Maintenance). If the condenser is dirty, have it cleaned by a specialist company or by the manufacturer.
- The device might carry out an automatic defrost. During automatic defrost, the device does not dehumidify.

### The device is loud or vibrates:

- Check whether the device is set up in a stable and upright position.

### Condensate is leaking:

- Check the device for leaks.

### The compressor does not start:

- Check the room temperature. Observe the device's permissible operating range according to the technical data.
- Ensure that the relative room humidity complies with the technical data.
- Check the preselected relative room humidity. The humidity in the room must be above the selected range.
- Check whether the overheating protection of the compressor has tripped. Disconnect the device from the mains and let it cool down for approx. 10 minutes before reconnecting it.
- The device might carry out an automatic defrost. During automatic defrost, the device does not dehumidify.

### The device gets very warm, is loud or is losing power:

- Check the air inlets and air filters for dirt. Remove external dirt.
- From the outside, check the device for dirt (see chapter Maintenance). If the inside of the device is dirty, have it cleaned by a specialist company for cooling and air-conditioning or by the manufacturer.

### The device still does not operate correctly after these checks:

Please contact the customer service. If necessary, bring the device to a specialist company for cooling and air-conditioning or to the manufacturer for repair.

## Maintenance

## Maintenance intervals

Maintenance and care interval	before every start-up	as needed	at least every 2 weeks	at least every 4 weeks	at least every 6 months	at least annually
Check air inlet and outlet for dirt and foreign objects and clean if necessary	X			X		
Clean the exterior		X				X
Visually check the inside of the device for dirt		X				X
Check the air filter for dirt and foreign objects and clean or replace if necessary	X		X			
Replace the air filter					X	
Check for damage	X					
Check the attachment screws		X				X
Test run						X
Empty and clean the condensation tank and/or drain hose		X				

## Maintenance and care log

Device type: .....

Device number: .....

Maintenance and care interval	1	2	3	4	5	6	7	8	9	10	11	12	13	14	15	16
Check air inlets and outlets for dirt and foreign objects and clean if necessary																
Check the air filter for dirt and foreign objects and clean or replace if necessary																
Clean the exterior																
Visually check the inside of the device for dirt																
Replace the air filter																
Check the attachment screws																
Test run																
Empty and clean the condensation tank and/or drain hose																
Comments																

1. Date: ..... Signature: .....	2. Date: ..... Signature: .....	3. Date: ..... Signature: .....	4. Date: ..... Signature: .....
5. Date: ..... Signature: .....	6. Date: ..... Signature: .....	7. Date: ..... Signature: .....	8. Date: ..... Signature: .....
9. Date: ..... Signature: .....	10. Date: ..... Signature: .....	11. Date: ..... Signature: .....	12. Date: ..... Signature: .....
13. Date: ..... Signature: .....	14. Date: ..... Signature: .....	15. Date: ..... Signature: .....	16. Date: ..... Signature: .....

**Activities required before starting maintenance**



**Warning of electrical voltage**

Do not touch the mains plug with wet or damp hands.

- Switch the device off.
- Hold onto the mains plug while pulling the power cable out of the mains socket.



**Warning of electrical voltage**

**Tasks which require the device to be opened must only be carried out by authorised specialist companies or by the manufacturer.**

**Refrigerant circuit**



**Danger**

**Natural refrigerant propane (R290)!**

H220 – Extremely flammable gas.

H280 – Contains gas under pressure; may explode if heated.

P210 – Keep away from heat, sparks, open flames and other ignition sources. No smoking.

P377 – Leaking gas fire: Do not extinguish, unless leak can be stopped safely.

P410+P403 – Protect from sunlight. Store in a well-ventilated place.

- The entire refrigerant circuit is a maintenance-free, hermetically sealed system and may only be maintained or repaired by specialist companies for cooling and air-conditioning or by the manufacturer.

**Safety signs and labels on the device**

Check the safety signs and labels attached to the device at regular intervals. Replace illegible safety signs!

**Cleaning the housing**

Clean the housing with a soft, damp and lint-free cloth. Make sure that no moisture enters the housing. Protect electrical components from moisture. Do not use any aggressive cleaning agents such as cleaning sprays, solvents, alcohol-based or abrasive cleaners to dampen the cloth.

**Visual inspection of the inside of the device for dirt**

1. Remove the air filter.
2. Use a torch to illuminate the openings of the device.
3. Check the inside of the device for dirt.
4. If you see a thick layer of dust, have the inside of the device cleaned by a specialist company for cooling and air-conditioning or by the manufacturer.

5. Put the air filter back in.

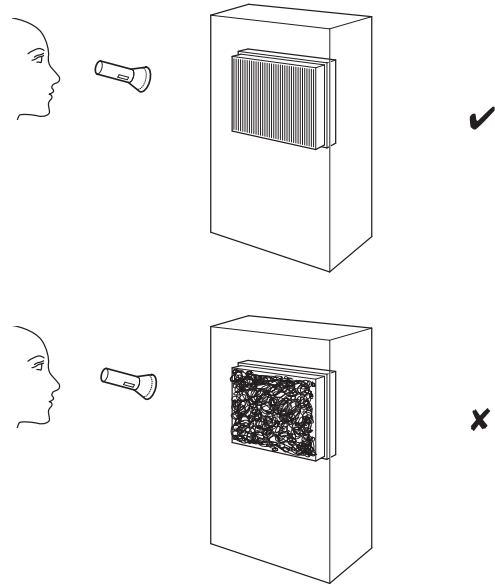

**Cleaning the air filter**

**Notice**

Ensure that the air filter is not worn or damaged. The corners and edges of the air filter must not be deformed or rounded. Before reinserting the air filter, make sure that it is undamaged and dry!

The air filter has to be cleaned as soon as it is dirty. This is brought to light e.g. by a reduced capacity (see chapter Errors and faults).

1. Remove the air filter from the device.

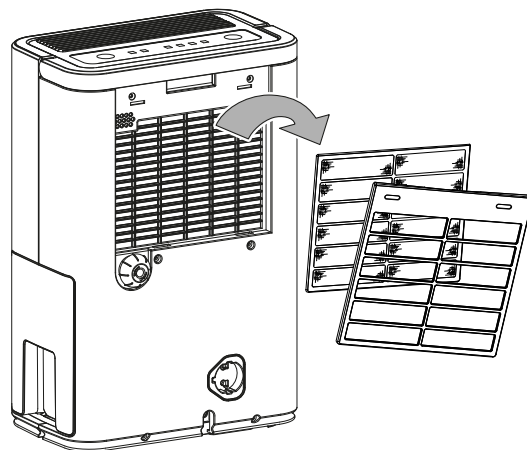

- Clean the filter using a slightly damp, soft, lint-free cloth. If the filter is heavily contaminated, clean it with warm water mixed with a neutral cleaning agent.

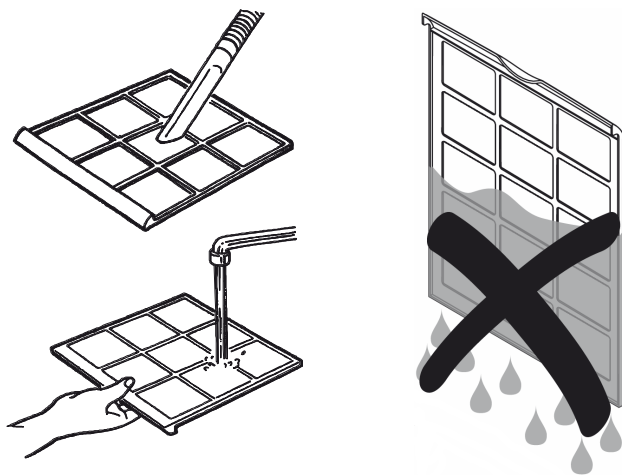

- Allow the filter to dry completely. Do not insert a wet filter into the device!
- Reinsert the air filter into the device.

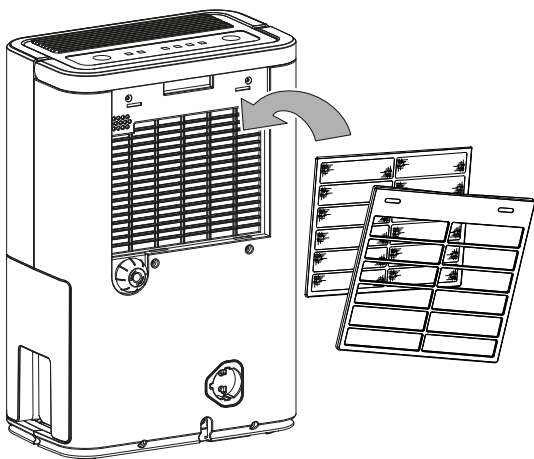

### Emptying the condensation tank

If the condensation tank is full or not installed correctly, the *BUCKET FULL* indication (12) will light up on the control panel. The compressor and fan will switch off.

- Take the condensation tank out of the device.

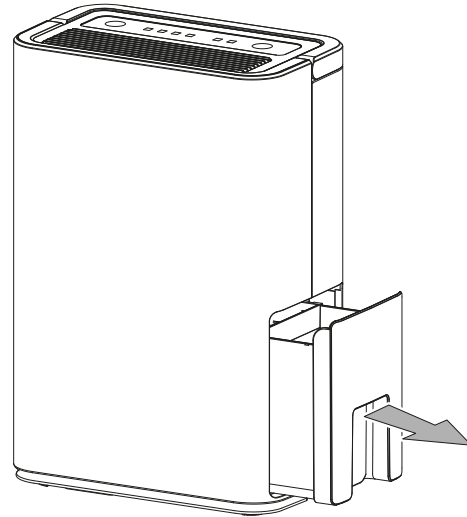

- Empty the condensation tank over a drain or sink.

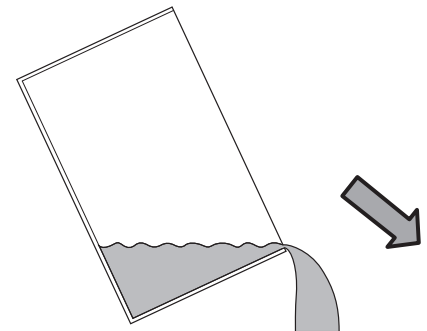

- Rinse the tank with clear water. Clean the tank regularly using a mild cleaning agent (no detergent!).

4. Refit the condensation tank into the device.  
 Make sure not to damage the float when inserting or removing the condensation tank.  
 In doing so, make sure that the float is positioned correctly.  
 Also make sure that the condensation tank is inserted correctly, otherwise the device cannot be switched back on.

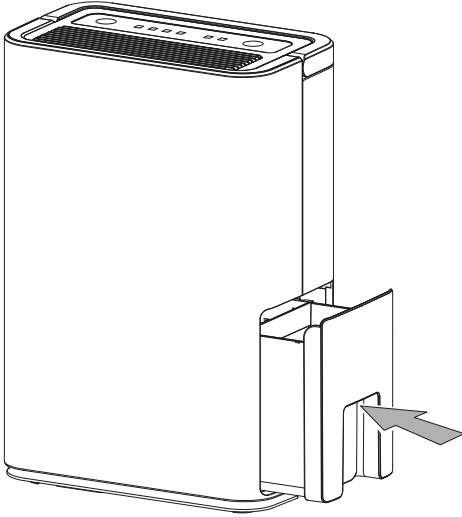

**Activities required after maintenance**

- If you want to continue using the device:
- Reconnect the device to the mains.
- If you do not intend to use the device for a considerable time:
- Store the device according to the Transport and storage chapter.

**Technical annex**

**Technical data**

Parameter	Value
<b>Model</b>	<b>TTK 52 E</b>
Max. dehumidification performance	16 l / 24 h
Dehumidification performance @ 30 °C and 80 % RH	14.7 l / 24 h
Air flow rate	110 m <sup>3</sup> /h
Operating range (temperature)	5 °C to 32 °C
Operating range (relative humidity)	30 % to 80 % RH
Suction side pressure	1.2 MPa
Discharge side pressure	2.4 MPa
Max. permissible pressure	2.6 MPa
Mains connection	220 – 240 V / 50 Hz
Max. power consumption	300 W
Nominal current	1.3 A
Fusing 	T 1 A / 250 V
Type of protection	IPX0
Refrigerant	R-290
Amount of refrigerant	85 g
GWP factor	3
CO <sub>2</sub> equivalent	0.000255 t
Water tank	2.4 l
Sound pressure level (at a distance of 1 m)	40 dB(A)
Dimensions (length x width x height)	194 x 304 x 467 mm
Minimum distance to walls and other objects	A: top: 40 cm B: rear: 20 cm C: side: 20 cm D: front: 20 cm
Weight	10 kg

Wiring diagram

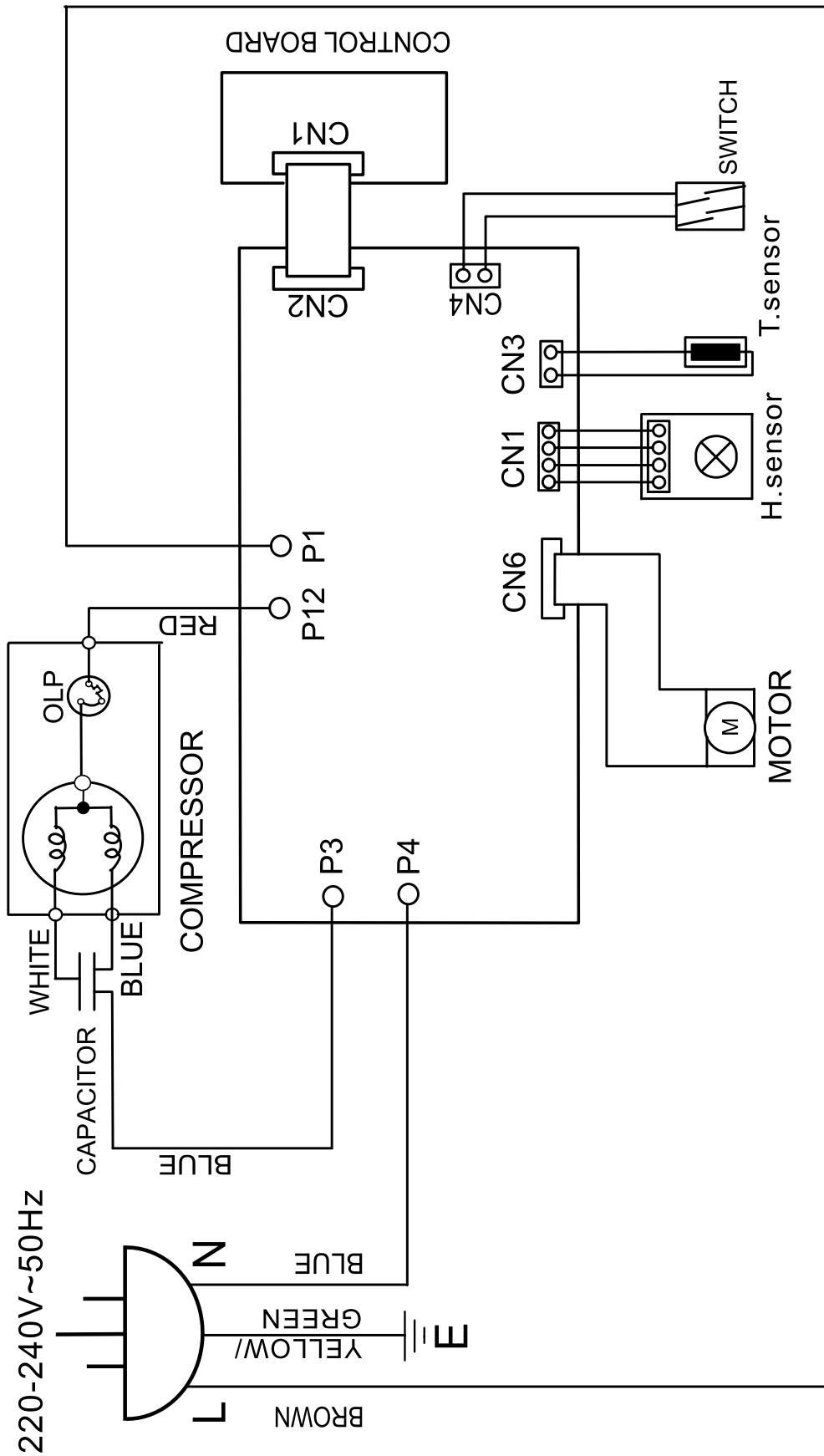

**Overview and list of spare parts**



**Info**

The position numbers of the spare parts differ from those describing the positions of the components mentioned in these instructions.

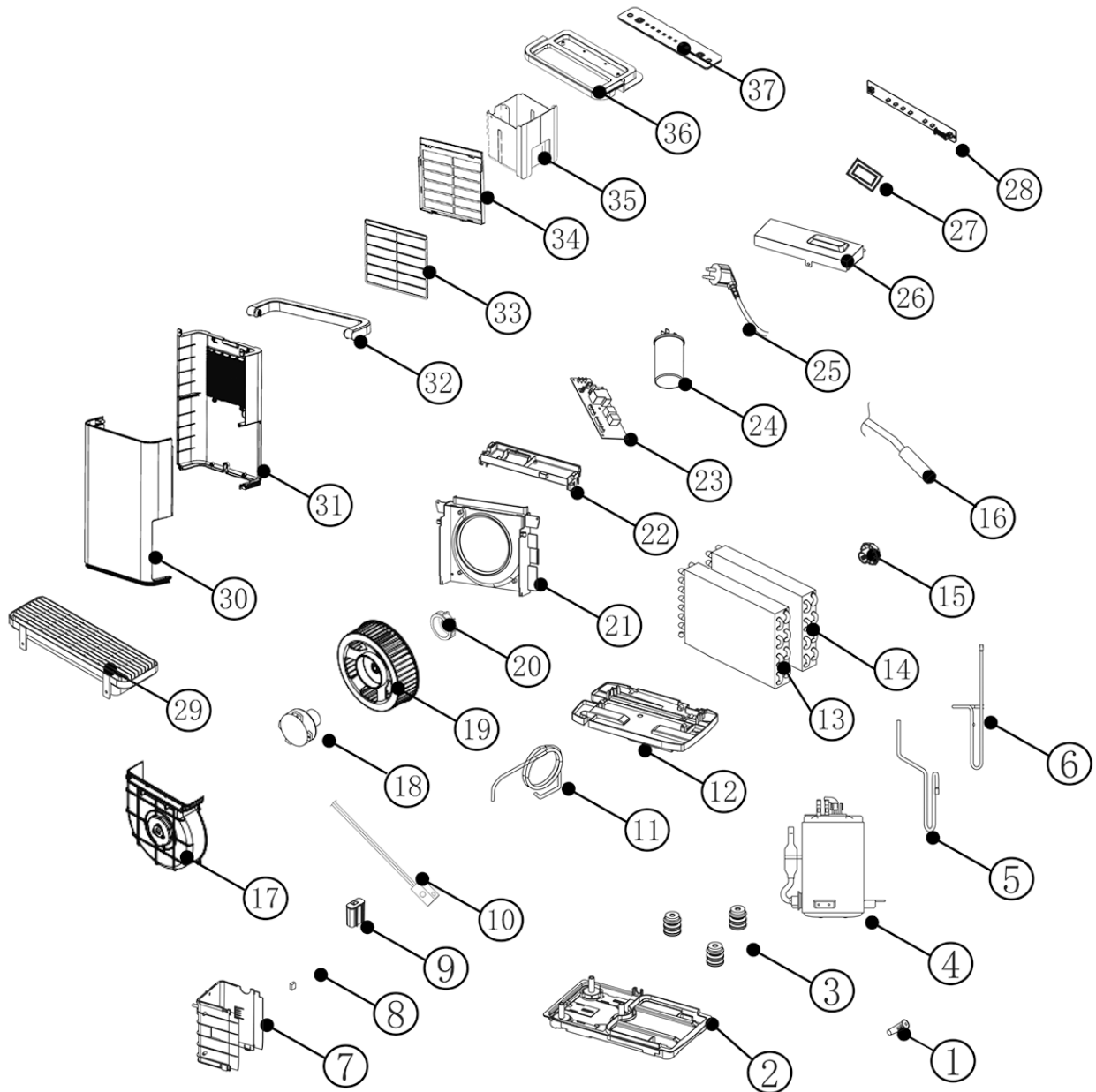

No.	Spare Part	No.	Spare Part	No.	Spare Part
1	Soft Cap	14	Evaporator Assembly	27	Sensor (For Humidity)
2	Base Pan	15	Plug	28	PC Board
3	Rubber	16	Sensor (For Indoor)	29	Discharge Grille
4	Compressor Assembly	17	Fan Casing	30	Front Panel
5	Suction Pipe	18	Fan Motor	31	Rear Panel
6	Discharge Pipe	19	Blower Wheel	32	Handle
7	Plate	20	Nut	33	Air Filter
8	Magnet	21	Fan Casing	34	Intake Grille
9	Tank Lid	22	Electric Box	35	Drain Bucket
10	Proximity Switch	23	Control Board	36	Top Cover Plate
11	Capillary Tube	24	Capacitor (8uF/450V)	37	Control Plate
12	Drainage Pan	25	Power Supply Cord Complete		
13	Condenser Assembly	26	Protect Cover		



## Disposal

Always dispose of packing materials in an environmentally friendly manner and in accordance with the applicable local disposal regulations.



The icon with the crossed-out waste bin on waste electrical or electronic equipment is taken from Directive 2012/19/EU. It states that this device must not be disposed of with the household waste at the end of its life. You will find collection points for free return of waste electrical and electronic equipment in your vicinity. The addresses can be obtained from your municipality or local administration. You can also find out about other return options that apply for many EU countries on the website <https://hub.trotec.com/?id=45090>. Otherwise, please contact an official recycling centre for electronic and electrical equipment authorised for your country.

The separate collection of waste electrical and electronic equipment aims to enable the re-use, recycling and other forms of recovery of waste equipment as well as to prevent negative effects for the environment and human health caused by the disposal of hazardous substances potentially contained in the equipment.

Have the refrigerant (propane) disposed of appropriately and according to the national regulations by a company with the relevant certification (European Waste Catalogue 160504).

### Only for United Kingdom

According to Waste Electrical and Electronic Equipment Regulations 2013 (SI 2013/3113) (as amended) and the Waste Batteries and Accumulators Regulations 2009 (SI 2009/890) (as amended), devices that are no longer usable must be collected separately and disposed of in an environmentally friendly manner.

Trotec GmbH

Grebener Str. 7  
D-52525 Heinsberg

☎ +49 2452 962-400

☎ +49 2452 962-200

✉ [info@trotec.com](mailto:info@trotec.com)

[www.trotec.com](http://www.trotec.com)