

# EN

**OPERATING MANUAL**  
LASER DISTANCE MEASURING  
DEVICE



**Table of contents**

Notes regarding the operating manual..... 2

Safety ..... 2

Information about the device..... 4

Transport and storage..... 5

Operation ..... 6

Maintenance and repair ..... 11

Errors and faults..... 12

Disposal ..... 12

**Notes regarding the operating manual**

**Symbols**

 **Warning of electrical voltage**  
This symbol indicates dangers to the life and health of persons due to electrical voltage.

 **Warning of laser radiation**  
This symbol indicates dangers to the health of persons due to laser radiation.

 **Warning**  
This signal word indicates a hazard with an average risk level which, if not avoided, can result in serious injury or death.

 **Caution**  
This signal word indicates a hazard with a low risk level which, if not avoided, can result in minor or moderate injury.

**Note**  
This signal word indicates important information (e.g. material damage), but does not indicate hazards.

 **Info**  
Information marked with this symbol helps you to carry out your tasks quickly and safely.

 **Follow the manual**  
Information marked with this symbol indicates that the operating manual must be observed.

You can download the current version of the operating manual and the EU declaration of conformity via the following link:



BD22



<https://hub.trotec.com/?id=45780>

**Safety**

**Read this manual carefully before starting or using the device. Always store the manual in the immediate vicinity of the device or its site of use.**

-  **Warning**  
**Read all safety warnings and all instructions.** Failure to follow the warnings and instructions may result in electric shock, fire and/or serious injury. **Save all warnings and instructions for future reference.**
- Do not use the device in potentially explosive rooms or areas and do not install it there.
  - Do not use the device in aggressive atmosphere.
  - Do not immerse the device in water. Do not allow liquids to penetrate into the device.
  - The device may only be used in dry surroundings and must not be used in the rain or at a relative humidity exceeding the operating conditions.
  - Protect the device from permanent direct sunlight.
  - Do not remove any safety signs, stickers or labels from the device. Keep all safety signs, stickers and labels in legible condition.
  - Do not open the device.
  - Avoid looking directly into the laser beam.
  - Never point the laser beam at people or animals.
  - Never charge batteries that cannot be recharged.
  - Different types of batteries and new and used batteries must not be used together.
  - Insert the batteries into the battery compartment according to the correct polarity.
  - Remove discharged batteries from the device. Batteries contain materials hazardous to the environment. Dispose of the batteries according to the national regulations.
  - Remove the batteries from the device if you will not be using the device for a longer period of time.
  - Never short-circuit the supply terminal in the battery compartment!

- Do not swallow batteries! If a battery is swallowed, it can cause severe internal burns within 2 hours! These burns can lead to death!
- If you think batteries might have been swallowed or otherwise entered the body, seek medical attention immediately!
- Keep new and used batteries and an open battery compartment away from children.
- Only use the device, if sufficient safety precautions were taken at the surveyed location (e.g. when performing measurements along public roads, on building sites etc.). Otherwise do not use the device.
- Observe the storage and operating conditions (see Technical data).

### Intended use

Only use the device for measuring distances, areas and volumes by means of the integrated laser and within the measuring range specified in the technical data. Observe and comply with the technical data.

To use the device for its intended use, only use accessories and spare parts which have been approved by Trotec.

### Foreseeable misuse

Do not use the device in potentially explosive atmospheres, or for measurements in liquids. Never point it at people or animals. Trotec accepts no liability for damages resulting from improper use. In such a case, any warranty claims will be voided.

Any unauthorised modifications, alterations or structural changes to the device are forbidden.

### Personnel qualifications

People who use this device must:

- be aware of the dangers that occur when working with laser measuring devices.
- have read and understood the operating manual, especially the Safety chapter.

### Residual risks



#### Warning of electrical voltage

There is a risk of a short-circuit due to liquids penetrating the housing!  
Do not immerse the device and the accessories in water. Make sure that no water or other liquids can enter the housing.



#### Warning of electrical voltage

Work on the electrical components must only be carried out by an authorised specialist company!



#### Warning of laser radiation

**Laser class 2, P max.: < 1 mW, λ: 400-700 nm, EN 60825-1:2014**

Do not look directly into the laser beam or the opening from which it emerges.

Never point the laser beam at people, animals or reflective surfaces. Even brief eye contact can lead to eye damage.

Examining the laser output aperture by use of optical instruments (e.g. magnifying glass, magnifiers and the like) entails the risk of eye damage.

When working with a laser of class 2, observe the national regulations on wearing eye protection.



#### Warning

Risk of suffocation!

Do not leave the packaging lying around. Children may use it as a dangerous toy.



#### Warning

The device is not a toy and does not belong in the hands of children.



#### Warning

Dangers can occur at the device when it is used by untrained people in an unprofessional or improper way! Observe the personnel qualifications!



#### Caution

Keep a sufficient distance from heat sources.

#### Note

To prevent damages to the device, do not expose it to extreme temperatures, extreme humidity or moisture.

#### Note

Do not use abrasive cleaners or solvents to clean the device.

**Information about the device**

**Device description**

The laser distance measuring device BD22 is used to determine distances, areas and volumes in interior spaces. Indirect measurements (e.g. height measurements of walls or furniture) are carried out using the Pythagoras function.

The integrated measuring wheel enables the measurement of curved lines, curves and circumferences. The timer allows to perform delayed measurements after 10 seconds.

The device is equipped with separate operating elements for the different measuring functions. The multi-line, backlit display indicates the determined values and measuring functions.

Measured values can be added or subtracted and up to 50 measurements can be retrieved from the data memory.

**Measuring distance**

The range of the device can be gathered from the Technical data chapter. Under certain conditions – e.g. at night, in twilight or when the target is hidden in the shade – greater distances are possible even without target plate. During the day use a target plate to increase the distance for poorly reflecting targets.

**Target surfaces**

There might be measurement errors when the laser encounters colourless liquids (e.g. water), dust-free glass, styrofoam or other semi-permeable materials. The measurement result may also be falsified if the laser encounters a high-gloss surface and is deflected by it. Non-glossy, non-reflective or dark surfaces can extend the measurement duration.

**Device depiction**

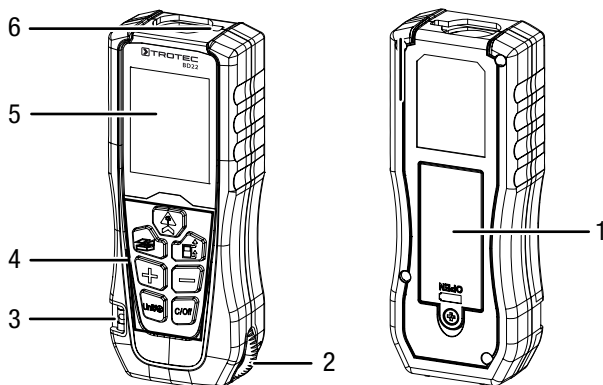

No.	Designation
1	Cover of the battery compartment
2	Measuring wheel
3	Spirit level
4	Operating elements
5	Display
6	Laser

**Operating elements**

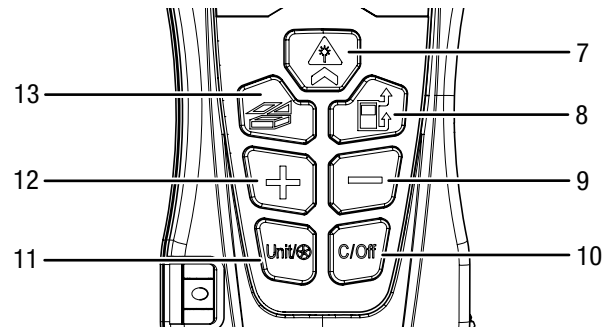

No.	Designation	Function
7	▲ button	Press briefly: switching the device on / measuring Press for a long time: starting continuous distance measurement
8	📏 button	Press briefly: change the reference point Press for a long time: call up history
9	- button	Press briefly: browse downwards in history Press for a long time: clear history
10	C/Off button	Press briefly: deleting last value Press for a long time: Switching the device off
11	Unit button	Press briefly: pin dimension measurement Press for a long time: change units (m/ft/ft+in/in)
12	+ button	Request next value in the history
13	🔄 button	Press briefly: change measuring mode Press for a long time: enable or disable acoustic signal

## Display

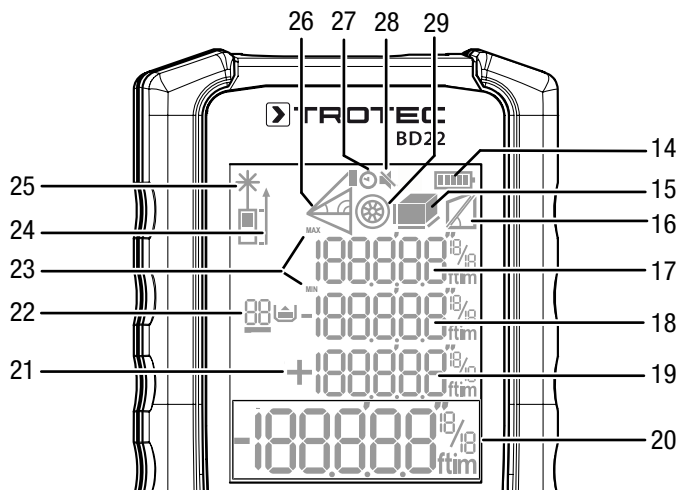

No.	Display element
14	Battery status
15	■ Area measurement
	■ Volume measurement
16	□ Trapezoidal measurement
17	Indication of measured value 1 (incl. unit)
18	Indication of measured value 2 (incl. unit)
19	Indication of measured value 3 (incl. unit)
20	Lower measurement value display: indicates the last measured value or the result of a calculation (incl. unit).
21	+/- indication: Addition/subtraction of measured values
22	Memory space indication
23	MAX/MIN indication
24	Reference point indication (front/rear)
25	Laser active
26	△ Indirect measurement (two auxiliary measurements)
	◁ Indirect measurement (three auxiliary measurements)
	▵ Indirect measurement of partial heights (three auxiliary measurements)
27	Timer indication
28	Acoustic signal indication on/off
29	⊗ Pin dimension measurement

## Technical data

Parameter	Value
Model	BD22
Weight	128.5 g
Dimensions (H x W x D)	130 x 51 x 28 mm
Measuring range of laser	0.05 to 50 m / 0.164 to 164 ft
Measuring range measuring wheel	0 to 10 m
Measuring units	m/ft/ft+in
Accuracy	±2 mm
Measuring range resolution	1 mm
Number of recordings logged in the history	50
Operating temperature	0 °C to 40 °C
Storage temperature	-10 °C to 60 °C
Relative humidity	max. 75 %
Laser output	< 1 mW (630-670 nm)
Laser class	II
Device switch-off	After approx. 3 minutes of non-use
Automatic switch-off of the laser	After approx. 30 seconds of non-use
Power supply	2 x 1.5 V battery (type AAA)

### Scope of delivery

- 1 x Device BD22
- 2 x 1.5 V battery AAA
- 1 x Quick guide

### Transport and storage

#### Note

If you store or transport the device improperly, the device may be damaged.

Note the information regarding transport and storage of the device.

### Transport

When transporting the device, ensure dry conditions and protect the device from external influences e.g. by using a suitable bag.

### Storage

When the device is not being used, observe the following storage conditions:

- dry and protected from frost and heat
- protected from dust and direct sunlight
- the storage temperature complies with the values specified in the Technical data

## Operation

### Inserting the batteries

#### Note

Make sure that the surface of the device is dry and the device is switched off.

1. Loosen the cover of the battery compartment (1) with a screwdriver.
2. Insert two batteries of type AAA (1.5 V, included in the scope of delivery) into the battery compartment with correct polarity (+/-).

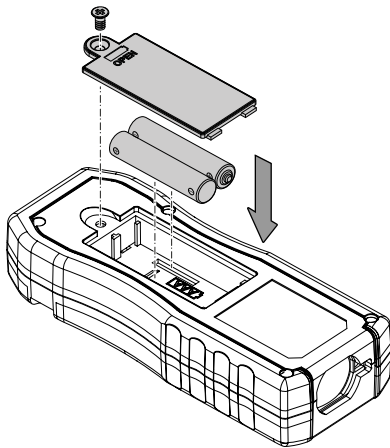

3. Put the cover of the battery compartment back onto the device and tighten it with the screws.

### Switch-on

1. Press the button (7) for approx. 1 second.  
⇒ The display will be switched on and the device ready for operation.

### Basic settings

#### Switching the acoustic signal on/off

1. Press the button (13) for a long time to switch the acoustic signal on or off.  
⇒ The switch-on/off process is confirmed by a brief acoustic signal.

#### Aborting the measurement and deleting the display

1. Briefly press the button (10) to abort the current measurement or to delete the displayed measured values one at a time.

### Adjusting the reference point

The device always measures the total distance starting at the reference point. This means that if the rear end of the device is set as reference point, the length of the device will be part of the measurement. By default the reference point is set to the rear of the device. You can, however, also relocate the reference point to the front part of the device. Please proceed as follows:

1. Press the button (8) to relocate the reference point to the front end of the device.  
⇒ An acoustic signal is emitted each time the reference point is relocated. In addition, the reference point display (24) indicates the selected reference point.

When switching the device off and then on again, the reference point will automatically be relocated to the rear end of the device.

### Changing the units

Press the button (11) for a long time to switch between the units for the measured values. You can set the following indications one after the other:

- 0.000 m (indication in metres, accuracy 1 mm)
- 0.00 m (indication in metres, accuracy 1 cm)
- 0.01 ft (indication in feet, accuracy 1/10 ft)
- 0' 0" <sub>1/8</sub> (indication in feet and 1/8 inch, accuracy 1/8 inch)
- 0.1 in (indication in inches, accuracy 1/10 inch)
- 0 1/8<sub>in</sub> (indication in inch and 1/8 inch, accuracy 1/8 inch)

### Calling up a measured value in the device history

The device automatically saves the last 50 measured values. The saved measured values can be called up as follows:

1. Press the button (8) for a long time to call up the history.
2. Briefly press the button (12) or the button (9) to navigate through the history and call up the saved measured values.
3. Press the button (9) for a long time to delete the saved measured values.
4. Briefly press the button, the button (13) or the button (10) to return to the measuring menu.  
Press the button (11) to return to the pin dimension measuring mode.  
Briefly press the button (10) to return to the laser measuring mode.



#### Info

It is not possible to save and call up measuring values when performing the pin dimension measuring mode.

## Carrying out measurements



### Warning of laser radiation

**Laser class 2, P max.: <math>< 1 \text{ mW}</math>,  $\lambda$ : 400-700 nm, EN 60825-1:2014**

Do not look directly into the laser beam or the opening from which it emerges.

Never point the laser beam at people, animals or reflective surfaces. Even brief eye contact can lead to eye damage.



Examining the laser output aperture by use of optical instruments (e.g. magnifying glass, magnifiers and the like) entails the risk of eye damage.

When working with a laser of class 2, observe the national regulations on wearing eye protection.

By pressing the  button (13) you can call up the following measuring modes one after the other:

- Single distance measurement:
  - you can add or subtract measured values
  - you can perform a non-stop measurement with MAX- /MIN-/current value
- Area measurement
- Volume measurement
- Indirect height measurement
- Twofold indirect height measurement
- Indirect measurement of a partial height
- Trapezoidal measurement
- Delayed measurement (starting after 10 seconds)
  - Use the + (12) and – buttons (9) to set the delay time between 5 and 60 s.

### Carrying out single distance measurement

1. Briefly press the  button (7) to activate the laser.
  2. Point the laser at the target area.
  3. Briefly press the  button (7) again to perform a distance measurement.
- ⇒ The measured value is indicated on the display.

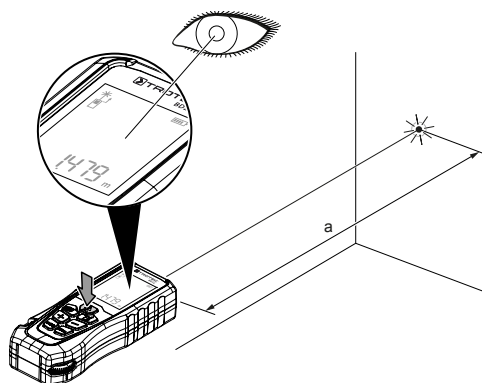

## Adding / subtracting measured values

1. Carry out a single distance measurement.
  2. Press the + button (12) to add the next measured value to the previous one.  
Press the – button (9) to subtract the next measured value from the previous one.
  3. Press the  button (7) to determine the next measured value.
- ⇒ The overall result will be indicated in the lower measurement value display. The individual measured values will be indicated in the upper measurement value displays.

## Performing a non-stop / min and max measurement

With this measurement method the device can be moved with the measured value being recalculated roughly every 0.5 seconds. You can use the non-stop measurement function with MAX/MIN/current value display for performing the following measurements, for example:

- **MAX value:** measuring a diagonal

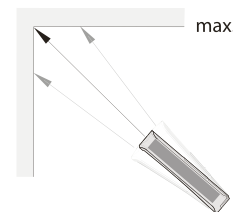

- **MIN value:** determining the perpendicular length to a wall/ floor area

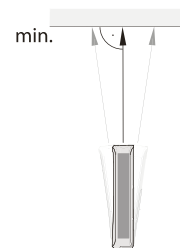

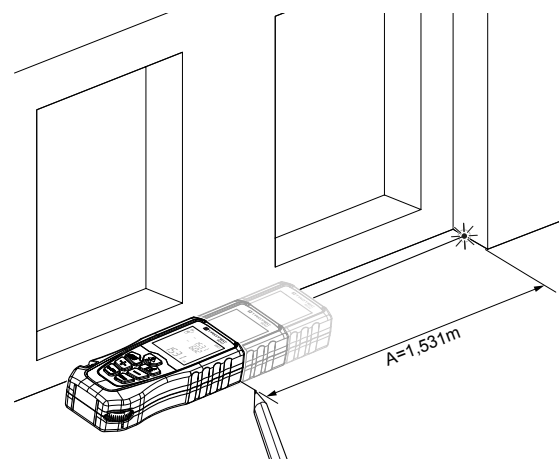

- **Actual value:** marking a defined value for a distance (e.g. a measurement from a ground plan)





1. Press the ▲ button (7) for a long time.
  - ⇒ With activated signal indication function, a recurring acoustic signal is emitted.
  - ⇒ The maximum, minimum and current value are indicated on the display.
2. Depending on the desired measurement, move the device slowly back and forth or up and down (e.g. in the corner of a room).
3. Briefly press the ▲ button to terminate the non-stop measurement.
  - ⇒ The maximum, minimum and last measured value are indicated on the display.

**Performing an area measurement**

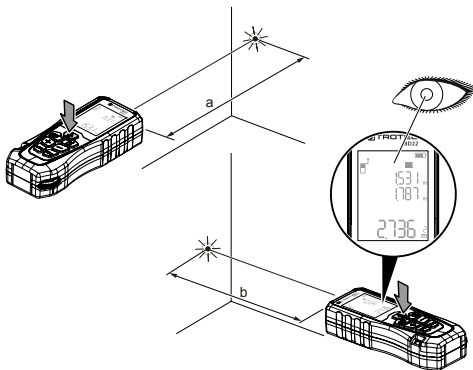
1. Press the  button (13) until the  symbol for the area measurement appears on the display.
2. Briefly press the ▲ button (7) to carry out the first measurement (e.g. length).
  - ⇒ The length of the line segment is displayed in the "Indication of the measured value 1" (17).
3. Briefly press the ▲ button (7) again to carry out the second measurement (e.g. width).
  - ⇒ The second measured value is displayed in the "Indication of measured value 2" (18).
  - ⇒ Upon pressing the ▲ button for the second time the device independently calculates the area and displays this value in the lower measured value indication (20).



**Performing a volume measurement**

1. Press the  button (13) until the  symbol for the volume measurement appears on the display.
  - ⇒ The side to be measured in each case is indicated on the display by flashing.
2. Briefly press the ▲ button (7) to carry out the first measurement (e.g. length).
  - ⇒ The length of the line segment is displayed in the "Indication of the measured value 1" (17).
3. Briefly press the ▲ button again to carry out the second measurement (e.g. width).
  - ⇒ The second measured value is displayed in the "Indication of measured value 2" (18).
4. Briefly press the ▲ button again to carry out the third measurement (e.g. height).
  - ⇒ The third measured value is displayed in the "Indication of measured value 3" (19).
  - ⇒ Upon pressing the ▲ button (7) for the third time the device independently calculates the volume and displays this value in the lower measurement value display (20).

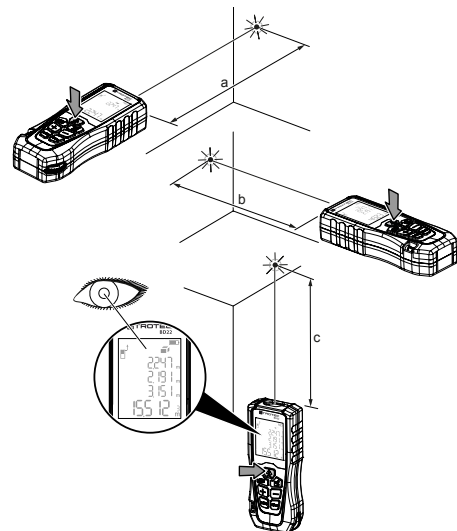



### Indirect height measurement (Pythagoras)

Using this method the length of an unknown straight-line segment can be determined via the Pythagorean Theorem. This method is suitable for e.g. height measurements.

The measurement result is calculated by determining the distances A and B.

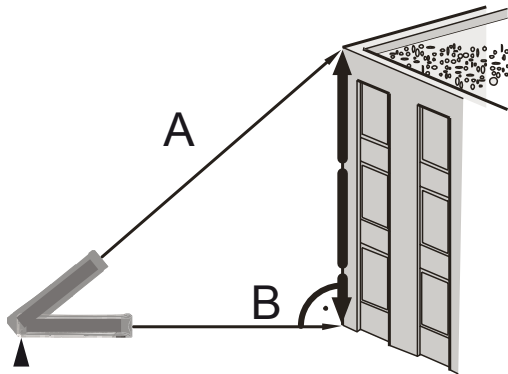

### Twofold indirect height measurement

This method is suitable for e.g. height measurements when you are not at the same height as the base point.

The measurement result is calculated by determining the distances A, B and C.

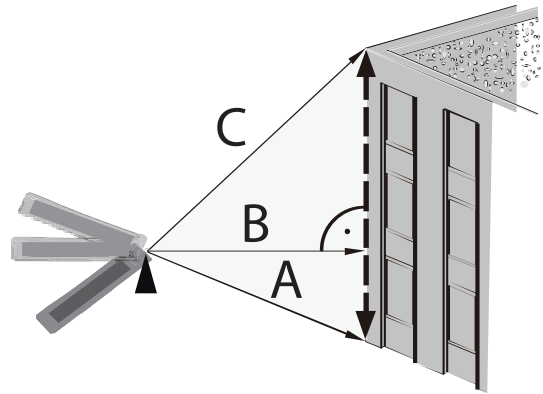

1. Press the button (13) until the symbol for the indirect measurement appears on the display.
  - ⇒ The upper bar (hypotenuse) flashes.
2. First, aim the device at the highest point (A) and briefly press the button (7) once to perform a measurement. Make sure to hold the device as steady as possible and place it level on the ground with the two rear edges. **The position at the two rear edges must not be changed during the measurements!**
  - ⇒ The length of the line segment is displayed in the "Indication of the measured value 1" (17).
3. Using the spirit level, align the device horizontally at the lower measuring point (B) and briefly press the button once to measure the horizontal distance.
  - ⇒ The second measured value is displayed in the "Indication of measured value 2" (18).
  - ⇒ The line segment to be determined is displayed as result in the lower measurement value display (20).

1. Press the button (13) until the symbol for the twofold indirect measurement appears on the display.
2. First, aim the device at the highest point (C) and briefly press the Switch-on/measurement button (7) once to perform a measurement. In doing so, hold the device as steady as possible. **The alignment of the device in relation to the reference point must not be changed during the measurements!**
  - ⇒ The length of the line segment is displayed in the "Indication of the measured value 1" (17).
3. Align the device horizontally (point B) and briefly press the button (7) one time to measure the horizontal distance.
  - ⇒ The second measured value is displayed in the "Indication of measured value 2" (18).
4. First, aim the device at the highest point (A) and briefly press the button once to perform a measurement.
  - ⇒ The third measured value is displayed in the "Indication of measured value 3" (19).
  - ⇒ The line segment to be determined is displayed as result in the lower measurement value display (20).

**Indirect measurement of a partial height**

This method is suitable for measuring partial heights (e.g. storey heights, window heights, etc.).

The measurement result is calculated by determining the distances A, B and C.

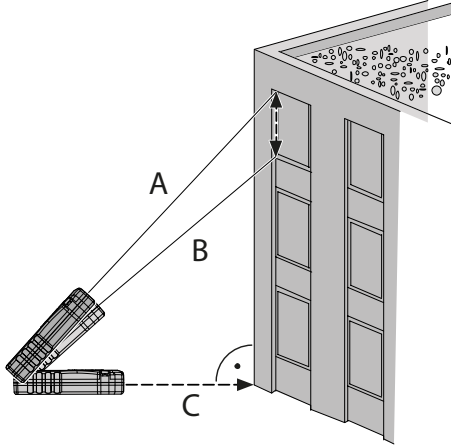

1. Press the button (13) until the symbol for the indirect measurement of a partial height appears on the display.
  - ⇒ The length of the line segment is displayed in the "Indication of the measured value 1" (17).
2. First, aim the device at the upper point (A) of the partial height to be measured and briefly press the button (7) once to perform a measurement. Make sure to hold the device as steady as possible. **The alignment of the device in relation to the reference point must not be changed during the measurements!**
  - ⇒ The second measured value is displayed in the "Indication of measured value 2" (18).
3. Now aim the device at the lowest point (B) of the partial height to be measured and briefly press the button (7) once to perform a measurement.
  - ⇒ The second measured value is displayed in the "Indication of measured value 2" (18).
4. Using the spirit level, align the device horizontally at the lower measuring point (C) and briefly press the button once to measure the horizontal distance.
  - ⇒ The third measured value is displayed in the "Indication of measured value 3" (19).
  - ⇒ The partial height to be determined is displayed as result in the lower measurement value display (20).

**Trapezoidal measurement**

The trapezoidal measurement allows you to determine the length of a roof slope from the ground, for example. To do so, please proceed as follows:

1. Press the button (13) until the symbol for the trapezoidal measurement appears on the display.
  - ⇒ The side to be measured in each case is indicated on the display by flashing.
2. Briefly press the button (7) to carry out the first measurement A (e.g. the height at the eaves).
  - ⇒ The length of the line segment is displayed in the "Indication of the measured value 1" (17).
3. Briefly press the button again to carry out the second measurement B (e.g. the horizontal section under the slope of the roof).
  - ⇒ The second measured value is displayed in the "Indication of measured value 2" (18).
4. Briefly press the button again to carry out the third measurement C (e.g. the height to the roof ridge).
  - ⇒ The line segment to be determined is displayed as result in the lower measurement value display (20).

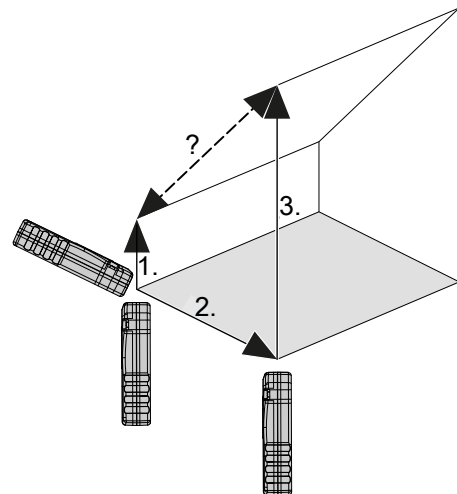

## Delayed measurement

With the delayed measurement you can e.g. determine the length up to a point if there is no obstacle for the laser to be aimed at (e.g. an outside corner of a building). To do so, please proceed as follows:

1. Press the button (13) until the number "10" and the symbol for the timer (27) appear on the display.
2. Use the + (12) and – buttons (9) to set the delay time between 5 and 60 s.
3. Position the device in a way that it is firmly placed on the ground and that measurements up to the desired point (e.g. horizontally) can be performed.
4. Briefly press the button (7) to activate the delayed measurement function.
  - ⇒ The countdown has started to slowly run down from the set time value.
5. Quickly move away from the device and place the obstacle at the target point. Make sure that the laser is visible on the obstacle.
  - ⇒ After the set time has elapsed, the device carries out the measurement.
  - ⇒ The measured line segment is displayed as result in the lower measurement value display (20).

## Pin dimension measurement

The measuring wheel (2) enables the measurement of curved lines, curve lengths or circle circumferences. To do so, please proceed as follows:

1. Briefly press the *Unit* button (11).
  - ⇒ The symbol for the pin dimension measurement (29) appears on the display.
2. Trace the contour to be measured (max. 10 m) with the pin dimension.
  - ⇒ The measured line segment is displayed as result in the lower measurement value display (20).

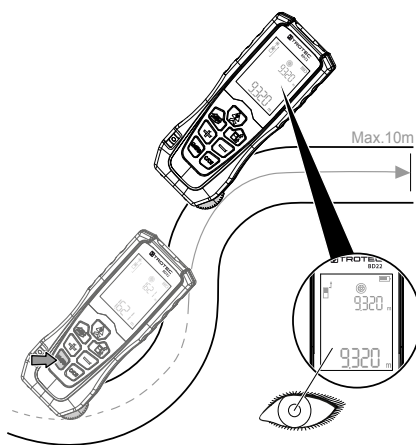

## Switch-off

1. Press the *C/Off* button (10) for a long time.
  - ⇒ The display is switched off.

## Maintenance and repair

### Battery change

#### Note

Make sure that the surface of the device is dry and the device is switched off.

A battery change is required when the error message 220 appears on the display or when the device can no longer be switched on (see chapter Inserting the batteries).

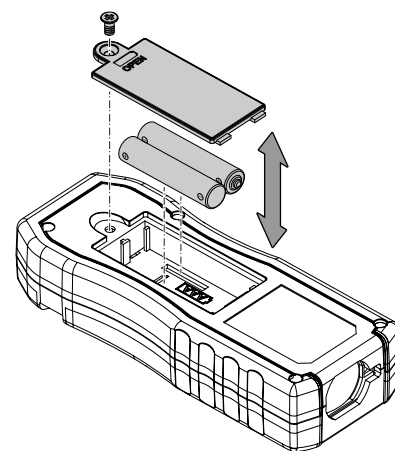

### Cleaning

Clean the device with a soft, damp and lint-free cloth. Make sure that no moisture enters the housing. Do not use any sprays, solvents, alcohol-based cleaning agents or abrasive cleaners, but only clean water to moisten the cloth.

### Repair

Do not modify the device or install any spare parts. For repairs or device testing, contact the manufacturer.



#### Info

Note down the result. The result will not be saved in the history.

3. Press the *C/Off* button (10) to return to the laser measuring mode.

## Errors and faults

The device has been checked for proper functioning several times during production. If malfunctions occur nonetheless, check the device according to the following list.

The following fault indications can appear in the lower measurement value display:

Display	Cause	Remedy
203	The temperature is too high.	Allow the device to cool down. Observe the permissible operating temperature according to the Technical data chapter.
220	The batteries are almost empty.	Change the batteries, see chapter Battery change.
254	Calculation error	Repeat the measurement. Pay attention to the measurement sequence and position of the device.
255	The reception of the reflected signal is too weak.	Repeat measurement on another surface with better reflective properties or use a target plate.
256	The reception of the reflected signal is too strong.	
258	Range exceeded	Observe the range values specified in the Technical data chapter.
301	Hardware fault	Repeatedly switch the device on and off. If the indication continues to appear, please contact the Trotec customer service.

## Disposal

Always dispose of packing materials in an environmentally friendly manner and in accordance with the applicable local disposal regulations.



The icon with the crossed-out waste bin on waste electrical or electronic equipment stipulates that this equipment must not be disposed of with the household waste at the end of its life. You will find collection points for free return of waste electrical and electronic equipment in your vicinity. The addresses can be obtained from your municipality or local administration. You can also find out about other return options that apply for many EU countries on the website <https://hub.trotec.com/?id=45090>. Otherwise, please contact an official recycling centre for electronic and electrical equipment authorised for your country.

The separate collection of waste electrical and electronic equipment aims to enable the re-use, recycling and other forms of recovery of waste equipment as well as to prevent negative effects for the environment and human health caused by the disposal of hazardous substances potentially contained in the equipment.



In the European Union, batteries and accumulators must not be treated as domestic waste, but must be disposed of professionally in accordance with Directive 2006/66/EC of the European Parliament and of the Council of 6 September 2006 on batteries and accumulators. Please dispose of batteries and accumulators according to the relevant legal requirements.

### Only for United Kingdom

According to Waste Electrical and Electronic Equipment Regulations 2013 (2013/3113) and the Waste Batteries and Accumulators Regulations 2009 (2009/890), devices that are no longer usable must be collected separately and disposed of in an environmentally friendly manner.

Trotec GmbH

Grebbener Str. 7  
D-52525 Heinsberg

☎ +49 2452 962-400

☎ +49 2452 962-200

✉ [info@trotec.com](mailto:info@trotec.com)

[www.trotec.com](http://www.trotec.com)