

# TTW 25000 S / TTW 35000 S

**EN**

**INSTRUCTIONS**  
WIND MACHINE

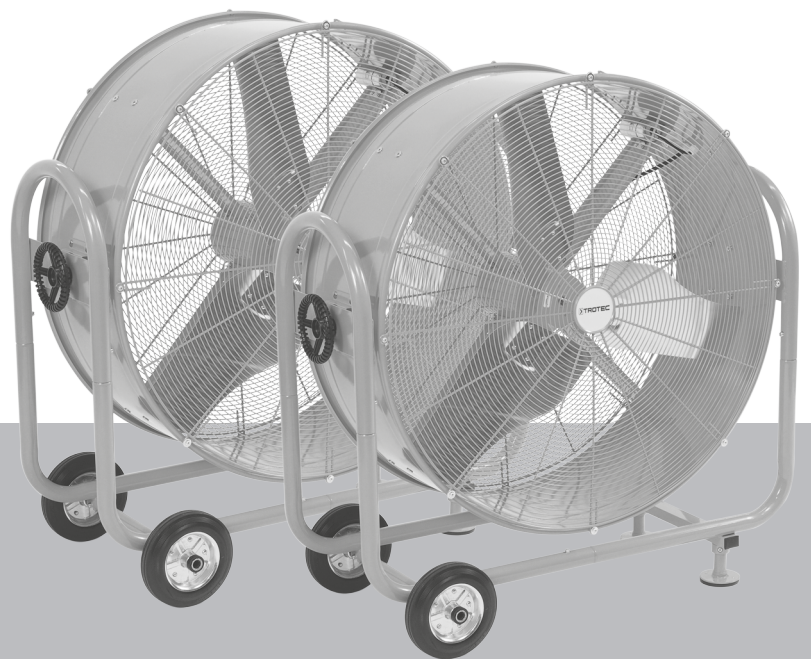

**Table of contents**

Notes regarding the instructions ..... 2

Safety ..... 2

Information about the device ..... 5

Transport and storage ..... 6

Assembly and start-up ..... 6

Operation ..... 8

Errors and faults ..... 8

Maintenance ..... 9

Technical annex ..... 10

Disposal ..... 12

You can download the current version of the instructions and the EU declaration of conformity via the following link:



TTW 25000 S



<https://hub.trotec.com/?id=42732>

TTW 35000 S



<https://hub.trotec.com/?id=42733>

**Notes regarding the instructions**

**Symbols**



**Warning of electrical voltage**

This symbol indicates dangers to the life and health of persons due to electrical voltage.



**Warning**

This signal word indicates a hazard with an average risk level which, if not avoided, can result in serious injury or death.



**Caution**

This signal word indicates a hazard with a low risk level which, if not avoided, can result in minor or moderate injury.

**Note**

This signal word indicates important information (e.g. material damage), but does not indicate hazards.



**Info**

Information marked with this symbol helps you to carry out your tasks quickly and safely.



**Follow the manual**

Information marked with this symbol indicates that the instructions must be observed.



**Wear safety glasses**

Information marked with this symbol indicates that you should wear eye protection.

**Safety**

**Read this manual carefully before starting or using the device. Always store the manual in the immediate vicinity of the device or its site of use.**



**Warning**

**Read all safety warnings and all instructions.**

Failure to follow the warnings and instructions may result in electric shock, fire and/or serious injury.

**Save all warnings and instructions for future reference.**

This appliance can be used by children aged from 8 years and above and persons with reduced physical, sensory or mental capabilities or lack of experience and knowledge if they have been given supervision or instruction concerning use of the appliance in a safe way and understand the hazards involved.

Children shall not play with the appliance. Cleaning and user maintenance shall not be made by children without supervision.



**Warning**

**Do not tilt the fan during operation.**

Make sure to always switch the device off, before adjusting the inclination angle.

Please observe the warning on the device.

- Do not use the device in potentially explosive rooms or areas and do not install it there.
- Do not use the device in aggressive atmosphere.
- Only put up the device in an upright, stable position on firm ground.
- Let the device dry out after a wet clean. Do not operate it when wet.

- Do not use the device with wet or damp hands.
- Do not expose the device to directly squirting water.
- Never insert any objects or limbs into the device.
- Do not cover the device during operation.
- Do not sit on the device.
- This appliance is not a toy. Keep away from children and animals.
- Check accessories and connection parts for possible damage prior to every use of the device. Do not use any defective devices or device parts.
- Ensure that all electric cables outside of the device are protected from damage (e.g. caused by animals). Never use the device if electric cables or the power connection are damaged!
- The mains connection must correspond to the specifications in the Technical annex.
- Insert the mains plug into a properly fused mains socket.
- Observe the technical data when selecting extensions to the power cable. Completely unroll the extension cable. Avoid electrical overload.
- Never use just one extension cable for the simultaneous operation of several fans.
- Do not kink the cable and prevent contact with oil, grease, chemicals, hot surfaces or sharp and abrasive objects.
- Before carrying out maintenance, care or repair work on the device, remove the mains plug from the mains socket. Hold onto the mains plug while doing so.
- Switch the device off and disconnect the power cable from the mains socket when the device is not in use.
- Do not under any circumstances use the device if you detect damages on the mains plug or power cable. If the power cable is damaged, it must be replaced by the manufacturer, its service agent or similarly qualified persons in order to avoid a hazard. Defective power cables pose a serious health risk!
- When positioning the device, observe the minimum distances from walls and other objects as well as the storage and operating conditions specified in the Technical annex.
- Make sure that the air inlet and outlet are not obstructed.
- Make sure that there are no loose items or dirt located in the immediate surroundings of air inlet and air outlet.
- Do not remove any safety signs, stickers or labels from the device. Keep all safety signs, stickers and labels in legible condition.
- Make sure that the suction side is kept free of dirt and loose objects.
- Do not transport the device during operation.
- Do not tilt the fan during operation. Make sure to always switch the device off, before adjusting the inclination angle.

### **Intended use**

Use the wind machine TTW 25000 S / TTW 35000 S for air circulation whilst adhering to the technical data and the safety instructions.

The device was designed for the generation of a powerful, large-volume air circulation, e.g. for the accelerated drying of buildings and rooms. The device is suited for both indoor and outdoor use.

Any use other than the intended use is regarded as misuse.

### **Reasonably foreseeable misuse**

The wind machine TTW 25000 S / TTW 35000 S is not suited for the installation in fluids or on flooded or boggy grounds.

Do not use this device in immediate proximity to bathtubs, showers or swimming pools.

Any unauthorised changes, modifications or alterations to the device are forbidden.

**Personnel qualifications**

People who use this device must:

- be aware of the dangers that occur when using high-performance fans.
- have read and understood the instructions, especially the Safety chapter.

**Safety signs and labels on the device**

**Note**

Do not remove any safety signs, stickers or labels from the device. Keep all safety signs, stickers and labels in legible condition.

The following safety signs and labels are attached to the device:

**STOP**  
Do not tilt during operation!

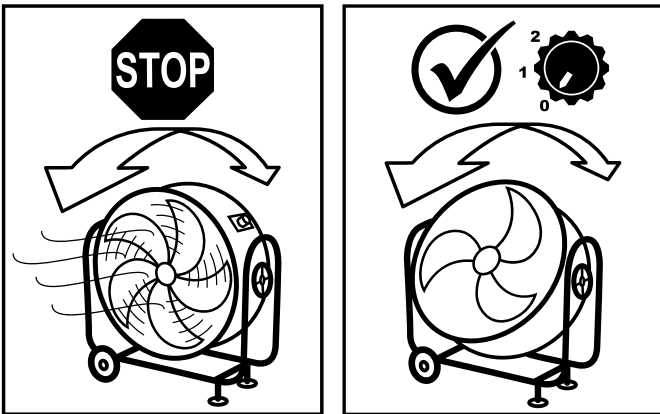

**DO NOT TILT DURING OPERATION!**

To tilt the device correctly and fix the inclination angle of the fan, proceed as described under Assembly and start-up.

Safety symbol	Meaning
	Wear eye protection when you are near the device.

**Residual risks**



**Warning of electrical voltage**

Work on the electrical components must only be carried out by an authorised specialist company!



**Warning of electrical voltage**

Before any work on the device, remove the mains plug from the mains socket!  
Do not touch the mains plug with wet or damp hands. Hold onto the mains plug while pulling the power cable out of the mains socket.



**Warning of electrical voltage**

Risk of electric shock!  
Risk of an electric shock if the device comes into contact with water!



**Warning**

Dangers can occur at the device when it is used by untrained people in an unprofessional or improper way! Observe the personnel qualifications!



**Warning**

The device is not a toy and does not belong in the hands of children.



**Warning**

Risk of suffocation!  
Do not leave the packaging lying around. Children may use it as a dangerous toy.



**Warning**

Only operate the device when the brakes are locked and the inclination adjustment mechanism is engaged!



**Caution**

Risk of injury from parts being whirled up!



Use suitable eye protection when you operate the device.



**Caution**

Risk of injury due to parts being whirled up by the strong air current.  
Before switching the device on, make sure that there are no loose parts (clothing, hair etc.) located near the air inlet or outlet!

**Note**

Do not use abrasive cleaners or solvents to clean the device.

### Behaviour in the event of an emergency

1. Switch the device off.
2. Disconnect the device from the mains feed-in: Hold onto the mains plug while pulling the power cable out of the mains socket.
3. Do not reconnect a defective device to the mains.

### Overheating protection

The device is equipped with an automatic overheating protection.

If the motor overheats (exceeds the operating temperature), the device will be switched off.

When the device has cooled down sufficiently, it will be switched back on.

No.	Designation
1	Air outlet
2	Wheels
3	Power cable with Schuko plug
4	Rotary switch for the <i>fan stage</i>
5	Handwheel
6	Chassis
7	Feet

## Information about the device

### Device description

The wind machine TTW 25000 S / TTW 35000 S was designed for a high air volume flow. The device is designed for indoor and outdoor air circulation tasks.

The ready-for-use device has a galvanized housing with chassis, which supports the adjustable two-stage fan in an inclinable drum. Thanks to the adjustable inclination angle, the wind machine can be variably aligned up to a vertical flow position.

The fan motor is equipped with an automatic overheating protection, which interrupts the power supply as soon as the device begins to overheat.

To make the device easier to transport, it is fitted with a transport handle and two wheels. Two feet with rubber buffers prevent the device from rolling away.

### Device depiction

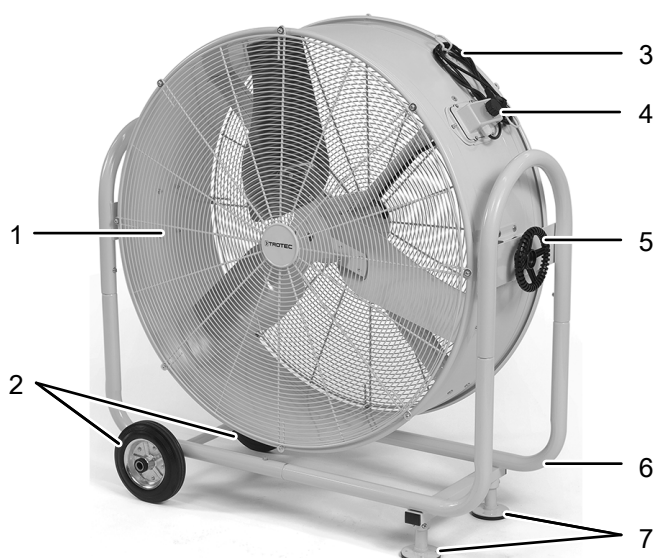

## Transport and storage

### Note

If you store or transport the device improperly, the device may be damaged.

Note the information regarding transport and storage of the device.

### Transport

To make the device easier to transport, it is fitted with a transport handle and wheels.

**Before** transporting the device, observe the following:

- Switch the device off.
- Hold onto the mains plug while pulling the power cable out of the mains socket.
- Do not use the power cable to drag the device.
- Only wheel the device on firm and level surfaces.

**After** transporting the device, proceed as follows:

- Set up the device in an upright position after transport.

### Storage

When the device is not being used, observe the following storage conditions:

- Store the device in a dry location and protected from frost and heat.
- If required, use a cover to protect the device from invasive dust.
- Place no further devices or objects on top of the device to prevent it from being damaged.

## Assembly and start-up

### Scope of delivery

- 1 x Device
- 1 x Manual

### Unpacking the device

1. Open the cardboard box and take the device out.
2. Completely remove the packaging.
3. Fully unwind the power cable. Make sure that the power cable is not damaged and that you do not damage it during unwinding.

### Assembly

1. Unpack the device, the wheels and front feet.
2. Place the device on level ground and carefully tilt it forward so that the tubular frame becomes accessible for mounting the wheels.



3. Remove the screws from the wheel assembly.
4. Attach the wheel assembly to the bottom of the tubular frame by aligning the holes in wheel assembly and tubular frame.
5. Refit the screws.

### Note

Make sure that the screws are tightened correctly and do not get jammed.

6. Make sure that the wheels are running freely.
7. Then bring the device back into an upright position.
8. Remove the screws of the front feet.
9. Insert the front feet into the connecting pieces at the bottom by aligning the holes in the feet and tubular frame.
10. Refit the screws.



## Start-up

When positioning the device, observe the minimum distance from walls or other objects as described in the chapter Technical annex.

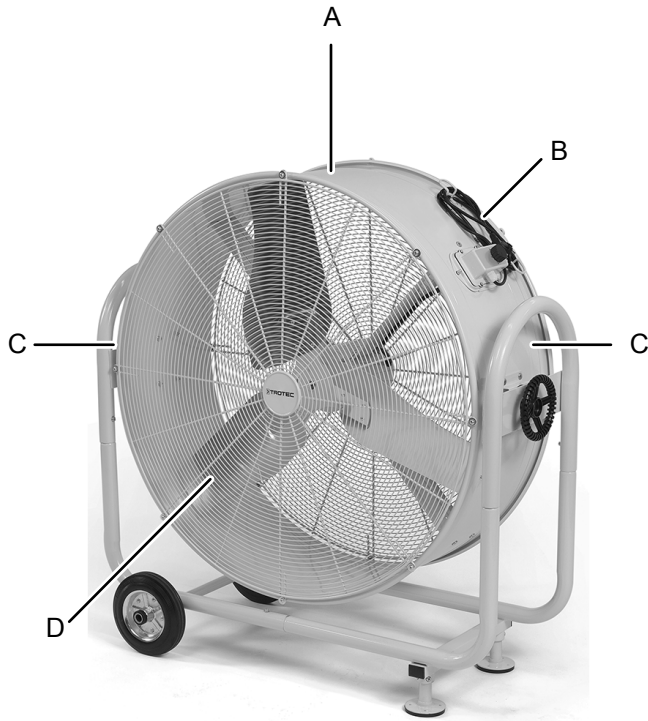

Please proceed as follows to adjust the inclination angle of the device:

1. Switch the device off by turning the rotary switch for the *fan stage* (4) to the **0** position.
2. Loosen the handwheel (5).  
⇒ The inclination angle can be adjusted in both directions up to the stop.
3. Retighten the handwheel.

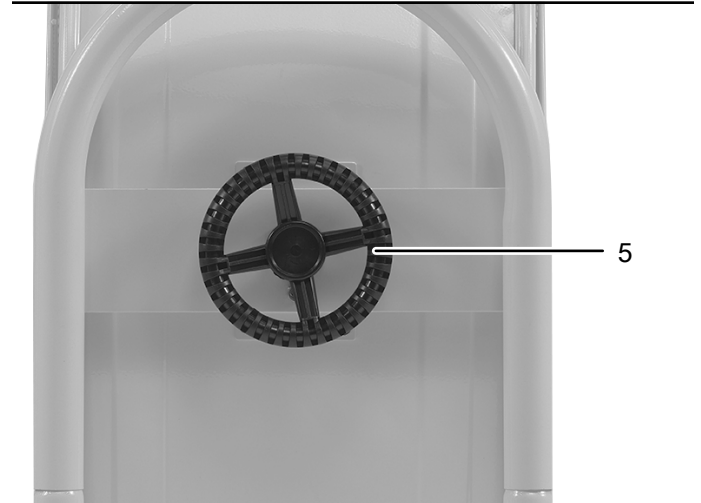

### Note

**Never go past the stop bolts when adjusting the fan position! Do not remove the stop bolts!**

- If a defect at the fan could cause property damage, we recommend the application of a suitable alarm system (air pressure switch, temperature sensor etc.).
- Before starting the device, check the condition of the power cable. If there are doubts as to their sound condition, contact the customer service.
- Only put up the device in an upright, stable position on firm ground.
- Make sure the device is only placed on firm, dry and vibration-free ground.
- Make sure that extension cables are completely unrolled.
- Make sure that the air inlet and outlet are not obstructed.
- When positioning the device, keep a sufficient distance to heat sources.
- Insert the mains plug into a properly fused mains socket.

**Operation**

**Operating elements**

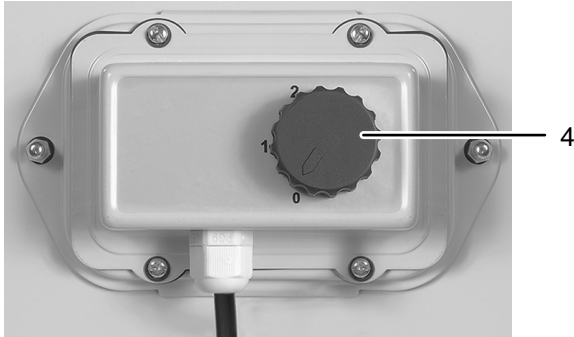

No.	Designation	Meaning
4	Rotary switch <i>Fan stage</i>	Setting the fan speed: stage <b>0</b> = off stage <b>1</b> = medium stage <b>2</b> = high

**Switching the device on**

- ✓ The device has been completely installed as described in the Assembly and start-up chapter.
  - ✓ The suction area (on the rear of the device) is free from dust, dirt and loose parts that can be drawn in.
  - ✓ The air outlet area is cleared from any obstacles.
1. Switch the device on by turning the rotary switch for the *fan stage* (4) to the desired position.
    - ⇒ **Note: Keep the suction area and air outlet area in view during operation. Switch off the device immediately if you recognise any hazards or if loose parts are drawn towards the fan.**

**Shutdown**



**Warning of electrical voltage**

Do not touch the mains plug with wet or damp hands.

1. Switch the device off by turning the rotary switch for the *fan stage* (4) to the **0** position.
2. Hold onto the mains plug while pulling the power cable out of the socket.
3. Clean the device according to the Maintenance chapter.
4. Store the device according to the Storage chapter.

**Errors and faults**

The device has been checked for proper functioning several times during production. If malfunctions occur nonetheless, check the device according to the following list.

**The fan is not running:**

- Check whether the device is switched on.
- Check the power connection.
- Check the power cable and mains plug for damages.
- Check the on-site fusing.

**The fan operates only for a brief period, then switches off:**

- Check whether the protective grid at the air inlet is obstructed in some way. If applicable, remove foreign objects.
- The motor bearing might be damaged. Please contact the customer service.

**The motor or fan is noisy or runs unevenly:**

- The fan is soiled. Clean the fan according to the Maintenance chapter.
- The fan or the blower unit is damaged. Please contact the customer service. If necessary, bring the device to an authorized specialist electrical company or to Trotec for repair.
- The motor bearing might be damaged. Please contact the customer service. If necessary, bring the device to an authorized specialist electrical company or to Trotec for repair.

**The fan produces grinding noises:**

- The fan blades are dirty or foreign objects are located in the rotation range of the fan. Clean the fan blades or the blower unit according to the Maintenance chapter.
- The fan blades might be damaged. Please contact the customer service. If necessary, bring the device to an authorized specialist electrical company or to Trotec for repair.



**The device vibrates heavily:**

- Check the floor space of the fan. Position the device on a level and firm surface.
- Check the screwed connections, particularly between blower unit and tubular frame. If necessary, retighten the screws.
- Check the fan blades for dirt and clean them if required.
- There might be an imbalance in the fan blades. Please contact the customer service. If necessary, bring the device to an authorized specialist electrical company or to Trotec for repair.

**The fan changes its position during operation:**

- Check the parking brakes for tight fit and retighten them if necessary.

**The air flow rate is low:**

- Check whether the protective grid is blocked and clean it if required.

**The device still does not operate correctly after these checks:**

Please contact the customer service. If necessary, bring the device to an authorised specialist electrical company or to Trotec for repair.

## Maintenance

**Activities required before starting maintenance****Warning of electrical voltage**

Do not touch the mains plug with wet or damp hands.

- Switch the device off.
- Hold onto the mains plug while pulling the power cable out of the mains socket.
- Allow the device to cool down completely.

**Cleaning the housing**

Clean the housing with a soft, damp and lint-free cloth. Make sure that no moisture enters the housing. Protect electrical components from moisture. Do not use any aggressive cleaning agents such as cleaning sprays, solvents, alcohol-based or abrasive cleaners to dampen the cloth.

**Cleaning the fan and device interior**

- Check fan and protective grid for perfect condition before and after each application.
- Clean the fan at regular intervals.
- Use compressed air to remove particles, lint, dust and dirt from motor, impeller and protective grid. Do not in any event use a high-pressure cleaner to clean the fan.
- If required during cleaning, remove the protective grid by unscrewing the eight screws, and put it back in its original place after the work has been completed.

**Technical annex**
**Technical data**

Parameter	Value		
Model	TTW 25000 S	TTW 35000 S	TTW 35000 S UK
Article number	1.510.004.020	1.510.004.025	1.510.014.026
Air volume:	level 1: 21000 m <sup>3</sup> /h level 2: 27600 m <sup>3</sup> /h	24600 m <sup>3</sup> /h 32400 m <sup>3</sup> /h	24600 <sup>3</sup> /h 32400 <sup>3</sup> /h
Max. air pressure	160 Pa	160 Pa	160 Pa
Voltage	230 V / 50 Hz	230 V / 50 Hz	110 V / 50 Hz
Power input:	level 1: 520 W level 2: 650 W	620 W 750 W	630 W 820 W
Fusing	16 A	16 A	16 A
Transport medium temperature	max. 40 °C	max. 40 °C	max. 40 °C
Sound level:	stage 1: 65 dB(A) level 2: 75 dB(A)	65 dB(A) 75 dB(A)	65 dB(A) 75 dB(A)
Type of protection	IP20	IP20	IP20
Mobility	Wheeled	Wheeled	Wheeled
Dimensions (L x W x H)	1060 x 525 x 1140 mm	1290 x 380 x 1210 mm	1290 x 380 x 1210 mm
Minimum distance to walls and other objects	50 cm top (A): 3 m rear / suction side (B): 50 cm At the sides (C): 50 cm front (D):	50 cm 3 m 50 cm 50 cm	50 cm 3 m 50 cm 50 cm
Weight	44 kg	49 kg	49 kg

Wiring diagram

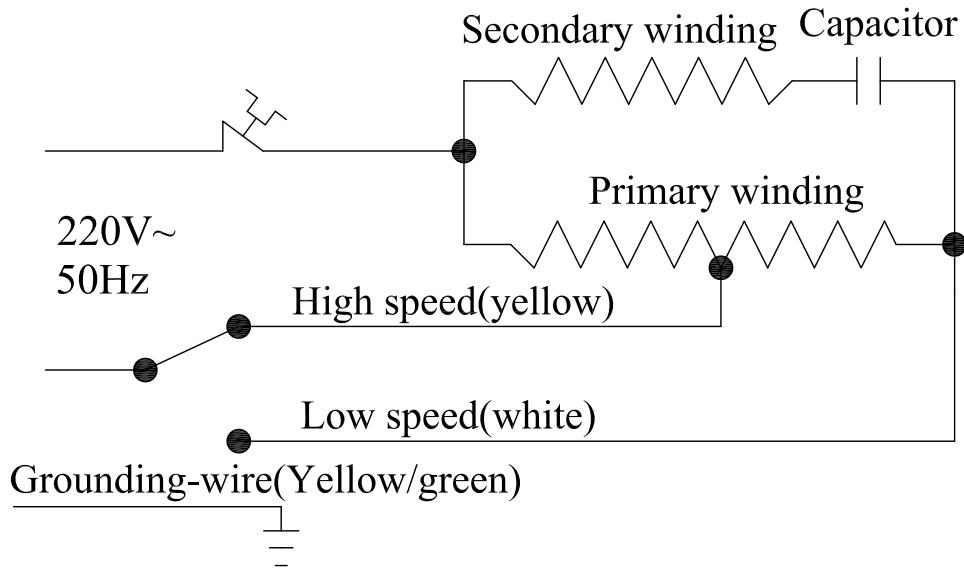

Overview and list of spare parts



Info

The position numbers of the spare parts differ from those describing the positions of the components mentioned in these instructions.

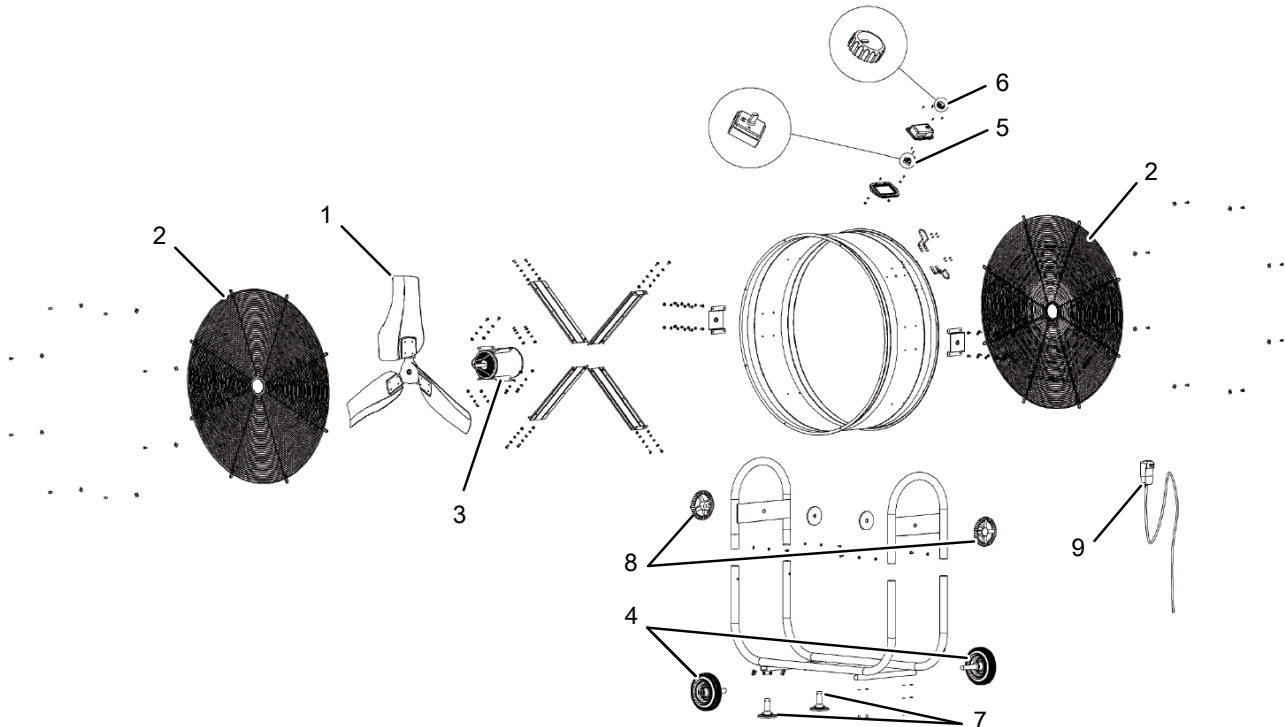

No.	Designation	No.	Designation	No.	Designation
1	Fan wheel	4	Wheels (pair)	7	Front feet (pair)
2	Protective grid	5	Switches	8	Inclination handwheel
3	Motor	6	Button/rotary control	9	Power cable

## Disposal

Always dispose of packing materials in an environmentally friendly manner and in accordance with the applicable local disposal regulations.



The icon with the crossed-out waste bin on waste electrical or electronic equipment is taken from Directive 2012/19/EU. It states that this device must not be disposed of with the household waste at the end of its life. You will find collection points for free return of waste electrical and electronic equipment in your vicinity. The addresses can be obtained from your municipality or local administration. You can also find out about other return options that apply for many EU countries on the website <https://hub.trotec.com/?id=45090>. Otherwise, please contact an official recycling centre for electronic and electrical equipment authorised for your country.

The separate collection of waste electrical and electronic equipment aims to enable the re-use, recycling and other forms of recovery of waste equipment as well as to prevent negative effects for the environment and human health caused by the disposal of hazardous substances potentially contained in the equipment.

### Only for United Kingdom

According to Waste Electrical and Electronic Equipment Regulations 2013 (SI 2013/3113) (as amended) devices that are no longer usable must be collected separately and disposed of in an environmentally friendly manner.

Trotec GmbH

Grebener Str. 7  
D-52525 Heinsberg

☎ +49 2452 962-400

☎ +49 2452 962-200

✉ [info@trotec.com](mailto:info@trotec.com)

[www.trotec.com](http://www.trotec.com)